

**PROPOSED REMEDIAL ACTION PLAN
TYSON WASH WQARF REGISTRY SITE
QUARTZSITE, ARIZONA
ADEQ TASK ASSIGNMENT 04-0048**

Prepared for:

**Arizona Department of Environmental Quality
Waste Programs Division
1110 West Washington
Phoenix, Arizona 85007**

Prepared by:

**MACTEC Engineering and Consulting, Inc.
3630 East Wier Avenue
Phoenix, Arizona 85040**

MACTEC Project No. 4972-07-2100.6.0



June 2, 2008



engineering and constructing a better tomorrow

June 2, 2008

Mr. Mike Beasley
Project Manager
Superfund Programs Section
Arizona Department of Environmental Quality
1110 West Washington Street
Phoenix, Arizona 85007

Subject: **Proposed Remedial Action Plan
Tyson Wash WQARF Registry Site
ADEQ Task Assignment 04-0048
MACTEC Project No. 4972-07-2100.6.0**

Dear Mr. Beasley:

MACTEC Engineering and Consulting, Inc. (MACTEC) is pleased to submit this *Proposed Remedial Action Plan* (PRAP) for the Tyson Wash WQARF Registry Site in Quartzsite, Arizona. This PRAP has been prepared in accordance with Arizona Administrative Code (A.A.C) R18-16-407(I) and selects the proposed remedial action for the Site.

Sincerely,

MACTEC ENGINEERING AND CONSULTING, INC.

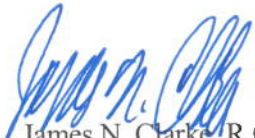
James N. Clarke, R.G
Principal Geologist



Expires 9/30/10

William G. Nesgood, R.G *with permission*
Senior Principal Geologist

P:\70211-4972\2007 Projects\4972-07-2100 - Tyson Wash 2008\PRAP\Tyson Wash WQARF PRAP.doc

TABLE OF CONTENTS

	Page
1.0 INTRODUCTION	1
1.1 PROJECT AUTHORIZATION.....	1
1.2 PURPOSE AND SCOPE OF THE PRAP.....	1
1.3 REPORT ORGANIZATION.....	2
2.0 BACKGROUND.....	3
2.1 SITE DESCRIPTION AND HISTORY	3
2.2 GEOLOGY AND HYDROGEOLOGY	6
2.3 CHRONOLOGY OF SITE ACTIVITIES.....	7
2.4 TYSON WASH POTENTIAL RESPONSIBLE PARTY INVESTIGATION	11
3.0 SELECTED REMEDY	12
3.1 SELECTED REMEDY	12
3.1.1 Remedial Strategy.....	14
3.1.2 Remedial Measures.....	14
3.1.3 Proposed System Operation.....	15
3.1.4 Source Control.....	16
3.1.5 Proposed Metrics	17
3.1.5.1 Groundwater Levels	17
3.1.5.2 Groundwater Quality Sampling.....	18
3.1.6 Uncertainties and Contingencies	18
3.2 ACHIEVEMENT OF REMEDIAL OBJECTIVES	20
3.2.1 Remedial Objectives for Land Use.....	20
3.2.2 Remedial Objectives for Groundwater Use.....	21
3.3 DEFINITION OF REMEDIATION AREAS.....	23
3.4 ACHIEVEMENT OF REMEDIAL ACTION CRITERIA PUSUANT TO ARS 49-282.06	24
3.5 CONSISTENCY WITH WATER MANAGEMENT PLAN	26
4.0 LIFE CYCLE COSTS.....	27
5.0 DISPOSITION OF TREATED WATER	31
6.0 CONCLUSIONS.....	32
7.0 REFERENCES	33

List of Tables:

Table 1.	Results of Depth to Groundwater Measurements, May 2000 – May 2007; Tyson Wash WQARF Site, Quartzsite, Arizona
Table 2.	Results of Groundwater Sample Analyses - Monitoring and Remediation Wells; Tyson Wash WQARF Site, Quartzsite, Arizona
Table 3.	Results of Groundwater Sample Analyses - Domestic Wells; Tyson Wash WQARF Site, Quartzsite, Arizona

List of Figures:

Figure 1 – Site Location Map

Figure 2 – Groundwater Elevation Hydrograph

Figure 3 – May 17, 2007 Groundwater Elevations

Figure 4 – 2nd Quarter 2007 PCE Concentrations

Appendices:

Appendix A – Remediation System Groundwater Modeling Results

Appendix B – Remediation System Construction Schematics

1.0 INTRODUCTION

This Proposed Remedial Action Plan (PRAP), prepared by MACTEC Engineering and Consulting, Inc. (MACTEC), relies upon the data and findings of the Remedial Investigation (RI) activities, Early Response Action (ERA) activities, and the Feasibility Study (MACTEC 2007) that have been conducted by the Arizona Department of Environmental Quality (ADEQ) since 1995. This PRAP outlines the proposed remedy that is capable of achieving the defined remedial objectives (ROs) to remediate the defined contamination at the Site. This PRAP has been prepared in accordance with the following guidance documents:

- Arizona Revised Statutes (ARS) §49-287.04(A), Proposed Remedial Action Plan;
- Arizona Administrative Code (A.A.C) R18-16-408 (March 29, 2002); and,
- *Guidance for Conducting Remedial Investigations/Feasibility Studies under CERCLA*, OSWER Directive 9355.3-01 dated October 1988.

1.1 PROJECT AUTHORIZATION

MACTEC Engineering and Consulting, Inc. (MACTEC) has been retained by the Arizona Department of Environmental Quality (ADEQ) to perform the following for the Site: a Remedial Investigation (RI); Human Health Risk Assessment (HHRA); Early Response Action (ERA), a Feasibility Study (FS); and preparation of this PRAP. This PRAP has been prepared in accordance with the scope of work and terms and conditions of the Arizona Superfund Response Action Contract (ASRAC) No. EV03-0073AO between MACTEC and ADEQ, and the ADEQ Task Assignment No. 04-0048.

1.2 PURPOSE AND SCOPE OF THE PRAP

The PRAP outlines and describes the selected remedy which has been shown in the FS to: 1) assure the protection of public health, welfare, and the environment; 2) to the extent practicable, provide for the control, management, or cleanup of hazardous substances so as to allow for the maximum beneficial use of waters of the State; 3) be reasonable, necessary, cost effective, and technically feasible; and 4) address any well that either supplies water for municipal, domestic, industrial, irrigation, or agricultural uses, or is part of a public water supply system, if the well

would now or in the foreseeable future produce water that would not be fit for its current or reasonably foreseeable end use without treatment.

The purpose of the PRAP is to present the selected remedy, which has been shown to satisfy the criteria presented above. Specifically, in accordance with §ARS 49-287.04(A), the PRAP must present and discuss:

1. The boundaries of the Site or portion of the Site that is the subject of the remedial action.
2. The results of the RI and FS.
3. The proposed remedy and its estimated costs.
4. How the remediation goals and selection factors in §ARS 49-282.06 and rules adopted by the Director have been considered.

The previously completed RI and FS Reports have documented the RI activities, the ERA that was implemented, and the proposed remedy, including estimated costs.

1.3 REPORT ORGANIZATION

The remaining portions of this PRAP have been organized into the following sections:

- Section 2.0 – SITE BACKGROUND – This section presents a summary of the Site description, physiographic setting, and the nature and extent of contamination.
- Section 3.0 – SELECTED REMEDY – This section presents the selected remedy, including the remedial strategy and remedial measures, and includes a discussion of the associated treatment technology and discusses how it will achieve the ROs and metrics to evaluate the system effectiveness.
- Section 4.0 – LIFE CYCLE COSTS – This section presents the costs associated with the selected remedy, based on the operational time estimate from the FS.
- Section 5.0 – DISPOSTION OF TREATED WATER – This section discusses how the treated water is managed.
- Section 6.0 – CONCLUSIONS – This section presents a concluding discussion of the proposed remedy for the Site.

2.0 BACKGROUND

The following description for the Site Background is taken from the *Remedial Investigation Report, Tyson Wash WQARF Registry Site, Quartzsite, Arizona* (RI Report) (MACTEC, 2003). The reader is directed to that report for a more detailed description of the Site.

2.1 SITE DESCRIPTION AND HISTORY

The Site is located northwest of the intersection of State Highway 95 and Business Route Interstate 10 in the Town of Quartzsite, La Paz County, Arizona. Quartzsite is located 125 miles west of Phoenix along U.S. Interstate 10, approximately 18 miles east of the Colorado River. The study area is located in the southeast quarter of Section 21, and the northeast quarter of Section 28, Township 4 North, Range 19 West, as shown on the Quartzsite, Arizona U.S. Geological Survey 7.5 minute Topographic Map (Figure 1). The WQARF study area includes several properties that contain both private residences and commercial businesses. The locations of properties, private wells, and monitoring wells within the Site are shown on Figures 1 and 3.

Investigation of the groundwater volatile organic compound (VOC) plume at the Tyson Wash WQARF Site was initiated by the Arizona Department of Environmental Quality (ADEQ) in August 1995. On June 30, 2003, MACTEC submitted the Final Remedial Investigation (RI) Report for the Tyson Wash WQARF Site. The RI focused on three properties shown on Figure 3: The Welcome RV Park; the former Hi-Ali Motel; and, the Cast (formerly Braswell) property. The greatest tetrachloroethene (PCE) concentration detected at the Site, which was 200 micrograms per liter ($\mu\text{g/l}$), was reported in the domestic well at the Welcome RV Park in 1995.

The VOC plume contains PCE and trichloroethene (TCE) at concentrations above the ADEQ Aquifer Water Quality Standard (AWQS) of 5 $\mu\text{g/L}$. The VOC plume has affected the upper aquifer, located approximately 40-70 feet below ground surface (bgs). There are no indications of the existence of non-aqueous phase liquids in soils or groundwater at the Site. VOC concentrations exceeding ADEQ Soil Remediation Levels have not been reported in any soil samples collected during the investigation. Historically, the shallow aquifer has been a source of drinking water for the area. In September 2001, the Town of Quartzsite completed the installation

of its municipal water supply, thus providing residents of the area with an alternate source of drinking water.

MACTEC began quarterly groundwater monitoring in November 1999. Depth to groundwater measurements were collected from dedicated dataloggers installed in each of the monitoring wells from May 2000 through November 2002. Manual measurements have been collected from the wells since December 2002. Monitoring results through the 3rd Quarter 2001 indicated a relatively consistent groundwater flow direction to the northeast. During the 4th Quarter 2001, the groundwater flow direction began to change toward the north-northwest. Table 1 provides well construction and groundwater elevation data through May 2007 and Tables 2 and 3 provide groundwater analytical data through May 2007. Figure 2 is a groundwater elevation hydrograph for the Site monitoring wells, Figure 3 shows the May 17, 2007 groundwater elevations, and Figure 4 shows the 2nd Quarter 2007 PCE distribution.

In February 2003, MACTEC, under authorization of ADEQ, implemented an ERA at the site. The ERA initially consisted of two components as follows:

- Performance of a bench-scale treatability study to evaluate in-situ anaerobic (oxygen depleted) bioremediation, also referred to as in-situ reductive dechlorination; and,
- Performance of pump-and-treat pilot test to evaluate the effectiveness of a groundwater pump and injection system to 1) reduce PCE concentrations in the Welcome RV Park well; 2) to mitigate migration of the plume in the downgradient direction to prevent impact to deep wells that may have been screened through the upper and lower aquifers; and, 3) assist in implementation of reductive dechlorination if selected as the remedy.

The results of the bench-scale treatability study and the pump-and-treat pilot test are described in the *Feasibility Study Report, Tyson Wash WQARF Registry Site, Quartzsite, Arizona* (FS Report) (MACTEC, 2007). In-situ bioremediation is a proven technology that can remediate a source zone in a short timeframe. Based on the results of the in-situ bioremediation treatability study, bioaugmentation combined with the addition of lactate as an electron donor was screened as a remedial alternative for both source control and plume remediation. The treatability study indicated bioaugmentation would likely achieve the ROs; however, due to the number of injection points required to deliver the *Dehalococcoides Ethenogenes* bacterium bacteria (DHE) to the aquifer, bioaugmentation may not be cost effective or as easily implemented compared to other remedial alternatives.

The following summarizes the Remedial Alternatives Evaluation (RAE) of in-situ bioremediation combined with pump-and-treat and long-term monitoring as a source control technology:

- In-situ bioremediation would require injection of DHE, along with an electron donor to stimulate and culture the DHE. In-situ bioremediation is considered somewhat practical for the Site because the remedial alternative can make use of the existing pump-and-treat system to deliver the electron donor. However, an estimated 100 injection points are required to deliver the DHE bacterium to the aquifer. This reduces the implementability and practicality of in-situ bioremediation when compared to pump-and-treat.
- The estimated cost to install, operate, and maintain an in-situ bioremediation system at the Site as a source control alternative is approximately \$1,000,000, not including costs for long-term plume area containment and monitoring. The total cost for the in-situ bioremediation system would exceed \$1,500,000.

When comparing the practicability, risk, cost, and benefit associated with bioremediation, and the ability to meet the ROs, pump-and-treat was evaluated as the reference alternative.

The groundwater pump-and-treat portion of the ERA originally consisted of the installation of two groundwater extraction wells, identified as EW-1 and EW-2, and an injection well, identified as INJ-1 on the Welcome RV Park property. Groundwater extracted from EW-1 and EW-2 was pumped through a granular activated carbon (GAC) filter and re-injected to the aquifer at INJ-1. The system was operated on a cycle of three hours on and three hours off to avoid creation of a groundwater mound. The system was started on April 7, 2003 and between April 7, 2003 and September 20, 2005, an estimated 2,909,487.3 gallons of groundwater had been pumped, treated in the GAC filter, and re-injected into the shallow aquifer through well INJ-1.

From February 2003 (baseline sampling event) to February 2005, the PCE concentrations in samples collected from the Welcome RV Park well decreased sharply from 160 µg/L to 30 µg/L, which indicated that the system was meeting the objective of decreased PCE concentrations in the Welcome RV Park well. However, PCE concentrations in QMW-1 and QMW-3 began steadily increasing. Based on the trends, it was concluded that the pilot-scale system had actually driven the PCE plume toward the south, toward QMW-1, and then northwest to QMW-3. Therefore, the objective of controlling plume migration was not being met. Based on this, MACTEC modeled an expanded system configuration consisting of three new extraction wells, identified as EW-3 through EW-5, and a new injection well, identified as INJ-2. The locations of these wells are shown on Figure 4 and the modeling results are attached as Appendix A.

The expanded system was installed from September 26, 2005 through October 5, 2005. Testing and adjustments were performed on October 11-12, 2005 and on October 18-20, 2005. Testing indicated that INJ-2 could not accept more than approximately 7 gpm of water. Therefore, the system was set on October 20, 2005 at a total pumping rate of 8 gpm on a cycle of 1 hour on and two hours off with 7 gpm of treated water injected at INJ-2 and 1 gpm of treated water injected at INJ-1. Between April 7, 2003 and May 15, 2007, a total of 4,961,219.5 gallons of water had been pumped and treated and approximately 1.06 pounds of PCE have been removed.

2.2 GEOLOGY AND HYDROGEOLOGY

At the Site, subsurface soils consist of two main units. From the ground surface to a depth ranging from 60 to 70 feet bgs, soils consist of interbedded layers of well-cemented gravel, sand, silt, and clay. The upper 20 to 25 feet of this unit generally contain silty sand and silty gravel. A lens of caliche occurs at a depth ranging from 8 to 12 feet bgs. The remainder of the upper unit consists of interbedded layers of silty clay and silty sand.

Below a depth ranging from 60 to 70 feet across the Site, soils consist of silty clay to clay, with the estimated clay percentage ranging from 50 percent (%) to nearly 100%. Groundwater flow in the upper aquifer is primarily horizontal through the coarser grained soils above the clay layer.

The shallow aquifer is believed to be perched and is estimated to extend at least 5 miles north of the Town of Quartzsite. A thick, extensive clay/limestone layer separates the shallow aquifer from a deeper confined aquifer. A vertical boring was drilled to a depth of 150 feet bgs to confirm the presence of the clay layer. The boring was terminated in the clay-rich unit. The deep aquifer consists of semi-consolidated sand, gravel, and clay that are typically encountered below 300 feet bgs. To date, there is no indication that the deep aquifer has been impacted with VOCs. There are over 540 wells within a ½ mile radius of the site. In order to determine if the wells in the surrounding area would not cause a cross contamination issue between the aquifers, the construction for each well would have had to be evaluated. Because of the unknown construction on wells in the area, there is a concern for cross-contamination.

Depth to groundwater at the Site ranges from approximately 41 to 55 feet bgs. Groundwater flow across the Site was generally toward the east-northeast between May 2000 and September 2001.

During that time period, the groundwater flow was strongly influenced by the pumping of domestic wells in the area.

There was a correlation between the seasonal changes in groundwater elevations and seasonal use of the domestic wells in the area. Between May and September 2000, the groundwater table elevation, as measured in monitoring wells QMW-1 through QMW-9 at the Site, generally increased or was relatively stable. Beginning in mid-October, and corresponding to the increased winter population, the groundwater table elevation decreased through March 2001, with the greatest change being noted in monitoring wells QMW-9 and QMW-2 on the Cast property. During April 2001, the water table decline ceased and elevations either stabilized or began to rise. This response corresponded to a decrease in water usage as the Town's population quickly declined near the end of March and early April. With the exception of the furthest upgradient wells (QMW-6 and QMW-7), the groundwater table elevation has increased steadily since the end of the Spring 2001 season. Depth-to-groundwater measurements collected since the 3rd Quarter 2001 also indicate a slight change in the groundwater flow direction toward to the north and northwest.

2.3 CHRONOLOGY OF SITE ACTIVITIES

To assist in reviewing the various investigation activities, this chronology was compiled of major investigation activities at the Site. The following outlines many of the events and investigative milestones for the project:

Date	Event
November 1993	ADEQ retains Groundwater Technologies, Inc. (GTI) to perform an investigation at Don's Café, which was located approximately 500 feet southeast of the current Cast property. Groundwater samples are collected from Cast well B-2. PCE and TCE are detected at concentrations of 39 µg/L and 0.7 µg/L in Cast well B-2.
June 1994	GTI, for ADEQ, re-samples Cast well B-2. PCE concentrations exceed AWQS of 5.0 µg/L.
February 1995	Former Hi-Ali Motel/Laundromat property and Cast Property are identified by ADEQ as potential hazardous waste sites.
July and August 1995	ADEQ initiates a Preliminary Investigation/Site Assessment (PA/SI) at the Hi-Ali property and collects groundwater samples from two former wells known as HA-1 and HA-2. PCE is detected in these wells above AWQS of 5.0 µg/L.

Date	Event
August 1995 through October 1997	ADEQ initiates a Preliminary Investigation/Site Assessment (PA/SI) at the Cast property in August 1995. The PA/SI concludes in October 1997. ADEQ collects groundwater samples from Cast wells B-1, B-2, B-3, and B-4. Well B-2 is the only well detected with PCE above AWQS of 5.0 µg/L. PCE is detected below AWQS of 5.0 µg/L in Cast wells B-1 and B-4.
November 1995	ADEQ collects a groundwater sample from the Welcome RV Park well. PCE is detected at a concentration of 200 µg/L.
March 1996	ADEQ installs two temporary wells on the Welcome RV Park property identified as HAP-9 and HAP-10. PCE was detected at a concentration of 76 µg/L in HAP-9 and at a concentration of 48 µg/L in HAP-10.
March 1996	ADEQ installs nine temporary wells on the Hi-Ali property identified as HAP-1 through HAP-8, and HAP-11. PCE concentrations range from laboratory non-detect to 34 µg/L.
May 1996	ADEQ drilled and sampled three soil borings at the Welcome RV Park property identified as SB-1, SB-3, and SB-4. Analytical results did not indicate VOC concentrations exceeding laboratory detection limits. At this time, ADEQ was also conducting investigations at the adjacent Cast property (see below). As part of this investigation boring JB1 was drilled on the Welcome RV Park property. A soil vapor sample collected from this boring was not detected with VOCs.
May 1996	Soil and soil vapor samples are collected from seven locations on the Cast Property. VOCs were not detected above laboratory reporting limits in the samples.
May 1996	ADEQ conducts additional soil, soil vapor, and groundwater sampling at the Hi-Ali property. Wells HA-1 and HA-2 are detected with 25 µg/L and 7.0 µg/L of PCE, respectively. Seventeen soil vapor samples are collected from borings HA1 through HA12, and HA18. Fourteen soil samples were also collected. VOCs were not detected above laboratory reporting limits in the soil and soil vapor samples.
April 1997 and March 1998	ADEQ supervises the installation of monitoring wells QMW-1, QMW-2, and QMW-3 in April 1997. ADEQ supervises installation of monitoring wells QMW-4 and QMW-5 in March 1998. These wells are sampled by ADEQ between July 1997 and May 1999.

Date	Event
March 1998	ADEQ performs an Expanded Site inspection (ESI) at Welcome RV Park. Eight soil vapor samples were collected from seven locations next to two on-site septic tanks. A total of five temporary wells (TYTI1 through TYTI5) were also installed and sampled and sludge samples were collected from the septic tanks. Soil vapor PCE concentrations ranged from 21 parts per billion vapor volume (ppbv) to 980 ppbv. PCE concentrations in the temporary wells ranged from 2 µg/L to 92 µg/L. The sludge samples were detected with 24 µg/L and 15 µg/L of PCE.
March 1998	ADEQ performs an Expanded Site inspection (ESI) at the Cast property. Soil and soil vapor samples were collected from three borings identified as TY19SV, TY20SV, and TY21SV. VOCs were not detected above laboratory reporting limits in the soil samples. PCE concentrations in the soil vapor samples ranged from 1.3 ppbv to 5.2 ppbv. ADEQ concluded the PCE in the soil vapor originated from the contaminated groundwater.
March 1998	ADEQ performs an Expanded Site inspection (ESI) at the Hi-Ali property. Soil vapor samples were collected from nine borings identified as TY9SV through TY12SV and TY14SV through TY18SV. A soil sample was collected from a boring identified as TYT6 and two sludge samples were collected from two septic tanks. PCE soil vapor concentrations ranged from 2.9 ppbv to 77 ppbv. PCE was detected at a concentration of 75 µg/L in the sludge sample collected from the southeast septic tank. VOCs were not detected in the other sludge sample or soil samples.
May 1998	The Welcome RV Park is identified by ADEQ as a potential hazardous waste site.
July 1995 – May 1999	ADEQ conducts groundwater sampling of 23 other production wells in the area that are not located on the properties discussed above.
December 1998	The Tyson Wash WQARF site is placed on the WQARF Registry List
September 1999	MACTEC is retained by ADEQ to perform the RI/FS/PRAP for the Site.
November 1999	MACTEC begins the RI by conducting a groundwater sampling event.
March and April 2000	Wells QMW-6, QMW-7, QMW-8, and QMW-9 are installed. Wells OB-1 through OB-3 are installed as observation wells for an aquifer test performed on QMW-7 and wells OB-4 and OB-5 are installed as observation wells for an aquifer test performed on QMW-6. Well QMW-10 is also installed in April 2000.

Date	Event
July 2000	A surface geophysical survey is performed by MACTEC to identify septic tanks, drain lines, and leach fields at Welcome RV Park and the Hi-Ali property.
August and October 2000	MACTEC collects soil and soil vapor samples from 18 borings identified as SV1 – SV18 on August 7-9, 2000. On October 26, 2000, an additional soil vapor boring identified as SV19 is drilled and sampled. A total of 36 soil vapor samples were collected. PCE soil vapor concentrations ranged from non-detect to 151 ppbv.
April 2001	MACTEC drills and samples temporary wells ESE-TY1 and ESE-TY2. PCE is detected at concentrations of 9.7 µg/L and 3.0 µg/L, respectively in TY1 and TY2.
May 2000 to April 2002	MACTEC conducts quarterly groundwater sampling of monitoring and production wells.
August 2002	ADEQ implements an ERA to provide source control and remediate groundwater below the Site.
October 2002	MACTEC submits Draft RI Report and Draft Land and Water Use Study Report to ADEQ.
February 2003	MACTEC implements the ERA at the Site. A pilot test groundwater pump-treat-and re-injection system is installed consisting of extraction wells EW-1 and EW-2 and injection well INJ-1. The remediation system consisting of granular activated carbon (GAC) treatment is installed at the location shown in Figures 2-4. A pre-pilot test (baseline) groundwater sampling event is performed and soil and groundwater samples for an in-situ bioremediation bench-scale treatability study are collected.
April 2003	The pilot groundwater pump-and-treat system is started.
May 2003	ADEQ prepares the Remedial Objectives (RO) Report.
June 2003	MACTEC submits Final RI Report and Final Land and Water Use Study Report to ADEQ.
May 2003 – September 2005	MACTEC performs quarterly groundwater sampling to evaluate the performance of the pilot groundwater pump-and-treat system.
October 2003	The In-situ Bioremediation Treatability Study Report is submitted to ADEQ.
September 2005	The groundwater pump and treat system is expanded to full-scale by adding extraction wells EW-3, EW-4, and EW-5 and injection well INJ-2. Baseline groundwater monitoring for the expanded system is performed.
October 2005	The full-scale groundwater pump-and-treat system is started.

Date	Event
December 2005 – present	MACTEC performs quarterly groundwater sampling to evaluate the performance of the groundwater pump-and-treat system.
June 2007	MACTEC submits the Final Feasibility Study Report to ADEQ.

2.4 TYSON WASH POTENTIAL RESPONSIBLE PARTY INVESTIGATION

A Remedial Investigation was conducted of the Tyson Wash WQARF Site. The results of the RI indicate that Tetrachloroethene (PCE) was released to the environment.

Pursuant to Arizona Revised Statutes 49-283, a potential responsible party (PRP) search was conducted. On review of the PRP Investigation Report and recommendation, the Attorney General’s Office advised that there is sufficient basis to determine that cost recovery is not appropriate at this site. Very little information is known about the date(s) or amount(s) of any release on any property. There is no information concerning who placed the PCE in the ground or groundwater under the property, or how.

Based on the information presented, there does not appear to be at least a viable responsible party. As the department’s duty to investigate is conditioned upon a determination that cost recovery may be appropriate, it follows that conducting a “best effort” search would be inappropriate unless at least one person is found from whom to recovery costs.

Based upon the limited financial assessment for each PRP, it does not appear that cost recovery is appropriate.

3.0 SELECTED REMEDY

3.1 SELECTED REMEDY

The groundwater beneath the Site is present in an upper aquifer which exists from 40 to 70 feet bgs and a lower aquifer which begins at approximately 300 feet bgs. The PCE and TCE groundwater plume identified at the Site appears to have only affected the upper aquifer. The extent of the plume, based on the May 2007 groundwater sampling event, is shown on Figure 4.

The Site includes nineteen privately owned wells, of which only one well (B-3) is constructed in the deep aquifer (Figure 4). No municipal or large supply wells are located on or near the Site. According to Arizona Department of Water Resources (ADWR) records, there are approximately 544 registered private wells within approximately a one-half mile radius of the Site. Approximately 111 of the 544 registered wells are deep aquifer wells.

Ten of the nineteen wells have been impacted by PCE contamination (see Table 3). Seven of the nine wells have historically had PCE concentrations above the AWQS of 5 µg/L (see Table 3). Three of the nineteen wells have been impacted by TCE contamination, of which one well has had historical TCE contamination above the AWQS of 5 µg/L. Groundwater pumped from the deeper aquifer currently provides the supply of water for the Town of Quartzsite.

ADEQ conducted a water use survey regarding the Site. A questionnaire was given to thirty-five residents within the community involvement area (CIA). Eighteen persons responded to the survey and submitted a written questionnaire for evaluation.

The results of the survey suggest that most residents within the CIA indicated they would continue to use their private wells for non-potable use. Four of the respondents indicated they would also continue using their wells for drinking water purposes. One respondent did not answer the future use question. One respondent indicated they were not sure if they would continue using their well in the future. One respondent stated that they used their well for domestic purposes and indicated they would discontinue use if connected to the Town of Quartzsite water supply. One other respondent indicated they would continue to use their deep aquifer well for potable purposes.

All of the commercial and residential properties located within the Site are connected to both Town of Quartzsite water and sewer. The Wellhead Protection Plan (WPP), as installed by the Town of

Quartzsite on September 14, 1999, outlined several management strategies for the Wellhead Protection Area (WPA). The WPP is enforced by the Town of Quartzsite and not by the State of Arizona. The WPP suggested that the Town require all property owners to disconnect shallow wells from drinking water connections once they have been connected to the Town's water system. The shallow wells could still be used for irrigation. The WPP also required that properties that desire to keep their privately owned wells install backflow prevention on their plumbing. The above two management strategies, if implemented, would deter private well owners from using their shallow wells as a drinking water source.

The following factors were taken into consideration when developing the ROs for the site:

- The Town of Quartzsite requires that all property owners within 200 feet of the water and sewer lines connect to the utilities provided.
- Some residents will continue to use their private wells for potable purposes due to taste issues resulting from high total dissolved solids (TDS) in the deep aquifer. However, residents who choose to use their private wells for potable purposes are required to isolate the private well water from the public supply distribution system.
- Elevated concentrations of TDS and nitrates occur in the shallow aquifer. Nitrate concentrations exceeding the Water Quality Standard of 10 milligrams per liter (mg/l) have been reported in groundwater samples collected from site monitoring wells. Nitrate concentrations range between 5 and 29 mg/l in groundwater beneath the site.
- As residents connect to the Town water system and discontinue use of their private wells, the plume geometry may change. Current groundwater analytical results indicate that the plume may be spreading toward Tyson Wash following the assumed natural direction of groundwater flow.
- All groundwater wells constructed within the deep aquifer may be possible conduits for cross-contamination between the two aquifers. Costs to evaluate deep wells as potential conduits are excessive and may exceed the cost required to cleanup the groundwater at the site.
- According to the WPP, installation of new wells in the shallow aquifer will be prohibited in the WPA. The WPP is enforced by the Town of Quartzsite and not by the State of Arizona.
- The WPA available at the time the RO Report was written does not include the Site. However, in the future additional areas just to the south of the Site may be established, as well as the entire community being declared a WPA.
- Shallow aquifer groundwater uses outside the boundaries of Site are assumed to be for potable use. This assumption is made because potential use of the shallow aquifer cannot

be determined without extensive outreach to each and every individual with a shallow groundwater well.

- ADEQ has not confirmed the connection status of other residents outside of the plume boundaries. Therefore, it is assumed for the purposes of developing the ROs that residents outside of the plume boundaries are continuing to use their domestic wells for potable purposes.
- After residents are connected to the Town of Quartzsite public water supply, it is assumed that the private domestic wells will be unnecessary for potable purposes. The WPP indicates that the management strategies suggested would deter people from using their private wells for potable purposes. According to the WPP, backflow prevention equipment must be installed on any private wells that the property owner wishes to use after service connection. In addition, the water service from the house must be connected to the Town water source.

3.1.1 Remedial Strategy

The remedial strategy for the Selected Remedy will be controlled migration to achieve the ROs. The Selected Remedy may also have the benefit of providing source control and ultimately plume remediation of contaminants of concern (COCs) to AWQSs over the long term. The COCs at the Site are identified as PCE and TCE.

3.1.2 Remedial Measures

The existing groundwater pump-and-treat system, which is the selected remedy, was installed as an ERA in September 2005 and has been in operation since October 2005. The remedial measures for the Selected Remedy will be as follows: 1) to pump groundwater from existing extraction wells (EWs) EW-1, EW-2, EW-3, EW-4, and EW-5; 2) treatment of the COCs by GAC; and, 3) re-injection of the treated water back into the aquifer at existing injection (INJ) wells INJ-1 and INJ-2. Remediated water is injected back to the aquifer per the Underground Injection Control (UIC) permit and in accordance with R18-16-408 (B4). The combined pumping and injection of the system controls downgradient migration of the plume by directing COC impacted water toward the extraction wells and flushing COCs from the saturated zone with the treated water. Monitoring of the system since October 2005 and groundwater modeling indicates this action will meet the ROs and may have the long term benefit of ultimately providing source control and plume remediation. The locations of the remediation wells and remediation system enclosure are shown on Figure 4. Construction schematics of the remediation system are attached in Appendix B.

In the future, based on groundwater monitoring results and with the authorization of ADEQ, the pump-and-treat system may be shut-down and natural attenuation be employed to meet the RO's. The discussion on the application of natural attenuation is presented in Section 3.1.5.

3.1.3 Proposed System Operation

On October 20, 2005, the full-scale system was started. The limiting factors for operation of the system are the pumping rate for an extraction well and the treated water injection rate to an injection well. The primary injection well is INJ-2. As shown in the construction schematics attached in Appendix B, the extracted groundwater is pumped through the GAC treatment and into an equalization tank. The treated water is then allowed to gravity feed to INJ-2. Testing of the system indicated that at a total pumping rate of eight (8) gpm from the five extraction wells, INJ-2 would fill to the top of the casing in less than one hour if 100 percent of the water is injected to INJ-2. The equalization tank would also fill to capacity in less than two hours. Further testing of the system indicated that by injecting 10 to 15 percent of the treated water to INJ-1, INJ-2 will fill to the top of the casing in approximately 75 minutes (1.25 hours) and approximately 120 minutes (two hours) were required for the well to drain to near static water levels. On March 30, 2006, MACTEC enhanced the system operation by installing a water level switch in the equalization tank and a secondary GAC scrubber was also installed. Additionally, in May 2006, MACTEC installed a remote monitoring and operation system known as an AlarmAgent. With the overflow protection systems installed on the system, the optimized 24-hour operation schedule was set on March 30, 2006 as follows:

0900 – 1015	ON
1015 – 1215	OFF
1215 – 1330	ON
1330 – 1530	OFF
1530 – 1645	ON
1645 – 1845	OFF
1845 – 2000	ON
2000 – 2200	OFF
2200 – 2315	ON
2315 – 0115	OFF
0115 – 0230	ON
0230 – 0500	OFF
0500 – 0630	ON
0630 – 0900	OFF

The last two “OFF” cycles are increased by 15 minutes to allow for stabilization of cumulative effects. This operation schedule results in the system being ‘ON’ for a maximum of nine hours during a 24-hour period; however, maximum water level system shut-downs, if they occur, will decrease the daily pumping time. These system shut-downs will be recorded by the remote operating system and can also be identified by recording the monthly quantity of water pumped. The pumping rates for wells EW-1 and EW-2 have been set by controller at 1.0 gpm and 2.0 gpm, respectively. The pumps installed in EW-3 through EW-5 are equipped with internal rate controllers that respond to back pressure. The pumping rates for wells EW-3 and EW-4 are set to vary from 2.0 to 2.5 gpm and the pumping rate for EW-5 is set to vary from 1.0 to 1.5 gpm. The designed total pumping rate for the five extraction wells is 8.0 gpm. However, the actual measured total pumping rate has stabilized at approximately 8.5 gpm. As COC concentrations decrease at EW-1 and EW-2, these wells may be taken off-line or pumping rates reduced and the pumping rates for EW-3 and EW-4 increased to enhance source control. However, the total pumping rate for the system currently will not exceed 8.5 gpm.

The system pumping rate may be adjusted in the future to optimize or increase the efficiency of the system. Adjustments and/or modifications to the system will be reported in periodic operation and monitoring reports.

3.1.4 Source Control

As shown on Figure 4, the boundaries of the plume have been established. There is currently no identified source area that contains vadose (unsaturated) zone soil contamination by COCs or non-aqueous phase COCs. The impact at the Site is apparently limited to dissolved and possibly sorbed COCs in the shallow saturated zone. A detailed discussion of the remediation area is provided in Section 3.3; however, the remediation area has been divided into two areas based on PCE concentrations. The “source” area is the area of groundwater containing concentrations of PCE that are greater than 50 µg/L. The “plume” area is the area of groundwater containing concentrations of PCE greater than the AWQS of 5.0 µg/L. Though source control is not the remedial strategy for the Selected Remedy, the Selected Remedy may have the long-term benefit of ultimately remediating the defined “source” area to concentrations of PCE below 50 µg/L.

3.1.5 Proposed Metrics

In accordance with A.A.C R18-16-408, Proposed Remedial Action Plan, the PRAP must discuss how the remedial action progress will be measured. To measure the progress of achievement of the ROs, MACTEC proposes that a combination of groundwater gradient measurements and groundwater sample analysis be conducted on an initial quarterly basis. The reason for this is discussed below in Section 3.1.6. The monitoring frequency may be reduced to a semi-annual basis after the “source” area is remediated to concentrations of PCE below 50 µg/L.

3.1.5.1 Groundwater Levels

MACTEC has been measuring water levels at the Site since May 2000. However, the groundwater measurements collected since December 2005 are the most representative to the operation of the remediation system.

Water levels in wells QMW-1, QMW-3, QMW-4, QMW-5, QMW-8, QMW-11, QMW-12, EW-1, EW-2, EW-3, EW-4, EW-5, INJ-1, and INJ-2 are measured while the system is “ON”. These wells were selected due to their locations within the area of influence of the remediation system and the water levels could be measured within or slightly after a one hour “ON” period. System “ON” gradient tracking for these wells evaluates the aquifer under dynamic conditions. The system “ON” groundwater measurements since December 2005 indicate the system is controlling plume migration as modeled and designed. The system “ON” groundwater measurements will continue to be collected on a quarterly basis until the groundwater monitoring frequency is reduced to a semi-annual basis. The system “ON” groundwater measurements will then continue to be collected on a semi-annual basis until system operation is terminated as indicated by groundwater quality sampling and authorized by ADEQ.

After the system “ON” water levels are measured and groundwater samples are collected from the extraction wells and treatment system, the system is turned “OFF” to allow for collection of groundwater samples from the monitoring wells and measurement of system “OFF” water levels. System “OFF” water levels are measured no less than 24-hours after system shut-down to evaluate the groundwater gradient under near-static conditions. Groundwater level measurements that have been collected since the 4th Quarter of 2001 have indicated a consistent westerly groundwater flow gradient in the southern portion of the Site and a consistent northerly groundwater flow gradient in the northern portion of the Site. Evaluation of the static groundwater gradient will become more

important in the future if the remediation system is shut-down and monitored natural attenuation (MNA) is implemented. Therefore, the system “OFF” groundwater measurements will continue to be collected on a quarterly basis until the groundwater monitoring frequency is reduced to a semi-annual basis. The system “OFF” groundwater measurements will then continue to be collected on a semi-annual basis until system operation is terminated as indicated by groundwater quality sampling and authorized by ADEQ.

3.1.5.2 Groundwater Quality Sampling

Groundwater quality sampling is likely the critical metric in evaluating the effectiveness of the system in meeting the ROs. The baseline groundwater sampling event for the operation of the current pump-and-treat system was performed in September and October 2005. Groundwater quality sampling from the monitoring, remediation, and private well network since the baseline event has shown changes in the groundwater impacted with PCE over time, including spatial and temporal changes. These samples will indicate whether the plume is expanding or contracting spatially, and how concentrations are changing with time. Groundwater sampling since the baseline event has shown that the remediation system is meeting the ROs and is operating as modeled and designed.

3.1.6 Uncertainties and Contingencies

Groundwater monitoring that has been performed since September 2005 has indicated that the current pump-and-treat system is meeting the ROs and is reducing dissolved COC concentrations within the plume. The single uncertainty identified at the Site is the continued rising groundwater levels. The lowest groundwater levels were measured at the Site during 2001. Since that time, groundwater levels have risen more than 8.5 feet and groundwater levels have been increasing annually between 0.5 feet and 1.0 foot (See Table 1 and Figure 2). A 20 year operation and maintenance (O&M) program was proposed in the FS. Therefore, if this trend continues, water levels may rise more than 10 feet over the 20 year program. Depth-specific groundwater samples are being collected from the well network. Therefore, the rising groundwater levels should not influence groundwater quality data. However, the rising groundwater levels may influence operation of the remediation system, particularly the re-injection of the treated groundwater back to the aquifer. The possible effect may be a reduction in the injection rate, which will result in the quantity of water that is pumped and treated possibly being reduced. The system is equipped with protection systems that prevent overflowing of the equalization tank. However, if the overflow

protection system is triggered, the amount of water pumped and treated is reduced. This is the reason why a quarterly monitoring program is proposed, at least over the short-term. In the future as dissolved PCE concentrations are decreased, extraction wells, particularly EW-1 and EW-2, may be taken off-line and the pumping rates for wells EW-3 and EW-4 increased. This may allow continued effective operation of the system while the water table rises. If the effectiveness is significantly reduced, the injection rate to INJ-1 can be increased, existing injection wells may require replacement, or additional injection wells installed.

Another uncertainty is the effectiveness of the pump-and-treat system to reduce dissolved PCE concentrations within the defined “source” area to below 50 µg/L. Though source control is not necessarily included in the remedial strategy, groundwater quality sampling has indicated the remediation system may remediate the defined “source” area to dissolved PCE concentrations below 50 µg/L in the long-term. Though groundwater pump-and-treat is proven to be an effective migration control remedial approach by removing dissolved-phase mass, it does not effectively remove contaminant mass sorbed to the soil. The soil flushing action provided by the treated water re-injection is intended to enhance removal of the sorbed contaminant mass, if appreciably present at the Site. Groundwater quality sampling has indicated a decreasing trend of PCE concentrations within the plume, currently ranging from 5.0 µg/L to 10 µg/L per quarter. This trend has been greater for some wells. For example; PCE concentrations in QMW-1 have decreased from 98 µg/L to 16 µg/L since September 2005, and PCE concentrations in QMW-3 have decreased from 200 µg/L in March 2006 to 93 µg/L in May 2007. MACTEC anticipates that the decreasing trend of dissolved PCE concentrations within the “source” area should slow down with time.

Another uncertainty is the influence of natural attenuation. Groundwater monitoring since September 2005 has indicated that the plume is relatively stable. This is due to natural attenuation at the edge of the plume enhanced by the operation of the pump-and-treat system. Natural attenuation may continue to provide plume migration control in the event the remediation system is temporarily or permanently shut down before PCE concentrations within the plume area are remediated below 5.0 µg/L. Based on the pre-remediation system groundwater monitoring data, this is a likely possibility. Prior to startup of the pilot system in 2003 and the full system in October 2005, natural attenuation by the physical processes of dilution, diffusion, volatilization, and sorption was apparently controlling migration of the plume. This was demonstrated by below AWQS concentrations of PCE in the Adams wells, the York well, and QMW-8 and QMW-10. However, natural attenuation by physical processes alone does not result in removal of contaminant

mass. Above AWQS concentrations of PCE were not detected in the York well and wells QMW-8 and QMW-10 until after the remediation system was started. This was predicted by the groundwater model as PCE was drawn from the Cast wells B-1 and B-2 toward EW-4 and EW-5.

3.2 ACHIEVEMENT OF REMEDIAL OBJECTIVES

The Remedial Objectives Report dated May 14, 2003 and prepared by ADEQ presents ROs for the Site (ADEQ 2003). The ROs established were used to develop the remedy for the Site. The FS evaluated specific remedial measures and strategies and identified a reference remedy and two alternative remedies capable of meeting the ROs. The FS also identified the proposed remedy and describes how the proposed remedy will meet the ROs.

The ROs are based on the current and reasonably foreseeable uses of land and the current and reasonably foreseeable beneficial uses of waters of the state identified in the Tyson Wash Use Report, dated September 13, 2002. ROs were not established for every use identified in the Use Report. The determination as to whether a use of the water was addressed was based on information gathered during the public involvement process, limitations of WQARF, and whether the use is reasonably foreseeable.

A public meeting was held on October 17, 2001 to discuss the Use Report and the proposed ROs. The Use Report was slightly modified as a result of the public meeting. As a result, ADEQ conducted another meeting on October 29, 2002 to discuss the proposed ROs. Comments on the Draft RO Report were accepted through November 29, 2002. After consideration by ADEQ, the final RO Report was prepared and dated May 14, 2003 (ADEQ, 2003).

3.2.1 Remedial Objectives for Land Use

The Site includes approximately 12 acres of low density residential and commercial properties. Land use within the Site includes residences, a mobile home park, a restaurant, and a former hotel. Future land use within the general Site area is expected to remain similar, but increase in density. The Quartzsite General Plan proposes a commercial development node at the intersection of Business Loop I-10 and Highway 95, just outside the southeast boundary of the Site.

RO's for land use are established for those properties known to be contaminated with a hazardous substance. However, laboratory analyses of soil samples and soil gas samples have not definitively identified areas of soil contamination within the Site. VOCs in the soil may have been present at one time, but now have appeared to have volatilized, degraded, or dispersed into the groundwater or environment after they were released.

Since there is no evidence of soil contamination present above soil remediation levels in the areas that have been investigated, an RO for land use is not warranted.

3.2.2 Remedial Objectives for Groundwater Use

The ROs for groundwater use at the Site are as follows:

1. Remedial Objective for Potable use of the Shallow Aquifer outside the Tyson Wash WQARF site Plume Boundaries prior to Town Water Supply Connection and Non-potable use after Town Water Supply Connection

The Town of Quartzsite requires all property owners within 200 feet of the water and sewer service to connect to the utilities provided. In the future it is anticipated that all residents within the Town of Quartzsite will be connected to the public drinking water system. According to the ADWR database, there are over 400 shallow aquifer wells within a one-half mile radius of the site.

The assumed current use of the shallow aquifer outside of the Tyson Wash WQARF site plume boundaries is for potable purposes for those residents not connected to the Town water supply. After residents outside of the Tyson Wash WQARF site plume boundaries have connected to the Town water supply, the future use of the shallow aquifer will be for non-potable purposes only. The proposed RO for potable and non-potable groundwater use of the shallow aquifer outside the plume boundaries is:

To protect, restore, replace, or otherwise provide a water supply for potable use by private well owners outside the current plume boundaries of the Tyson Wash WQARF site if the current use is impaired or lost due to contamination from the site. This RO is applicable until Town water service connections can

be confirmed. After the Town water connections are confirmed, the RO is to protect, restore, replace, or otherwise provide a water supply for non-potable use by private well owners outside the current plume boundaries of the Tyson Wash WQARF if the current use is impaired or lost due to contamination from the site. This RO is needed for as long as the wells are used for non-potable purposes and their use is threatened, impaired, or lost as a result of contamination from the Tyson Wash site.

2. Non-potable use of the Shallow Aquifer within the Tyson Wash WQARF Plume Boundaries by Currently Impacted Private Well Owners

Nine shallow privately-owned domestic wells located within the Tyson Wash site have been impacted by PCE groundwater contamination. All of the businesses and residences located within the Tyson Wash WQARF site are connected to the Town water supply. Of the wells that have been impacted Welcome RV, Rhoades/Day, and Adams have indicated that they will continue to use their private wells for non-potable purposes as defined above in Table 1.

The current and future use of the shallow aquifer within the Tyson Wash WQARF plume boundaries is for non-potable purposes. The current and future use is reasonably foreseeable. The proposed RO for non-potable shallow aquifer groundwater use by currently impacted private well owners is:

To protect, restore, replace, or otherwise provide a water supply for non-potable use by currently impacted private well owners within the Tyson Wash WQARF site if the current use is impaired or lost due to contamination from the site. Actions are needed for as long as the wells are used for non-potable purposes and their use is threatened impaired, or lost as a result of contamination from the Tyson Wash site.

3. Remedial Objective for Municipal use of the groundwater located in the deep aquifer

According to Figure 4 of the Land and Water Use Report (contained in the Final RI Report), there are 4 deep wells located within less than a 1/8 mile radius of the Tyson

Wash site. All of these wells could be considered threatened for groundwater contamination within the deep aquifer. There is concern regarding possible conduits from the shallow aquifer to the deep aquifer created from improper installation of deep wells. In order to make a determination regarding whether the deep wells are conduits, extensive studies of each deep well would be required to assure that a pathway has not been created.

The current use of the deep aquifer is for potable purposes. Potable groundwater use of the deep aquifer is considered reasonably foreseeable. The proposed RO for this use is:

To protect, restore, replace, or otherwise provide a water supply for potable use of the deep aquifer. These actions will continue for as long as contamination from the Tyson Wash site threatens the deep aquifer.

The remedial strategy for the Site is to control the migration of the COCs from the current plume boundaries to wells outside the current plume boundaries. The groundwater model and groundwater monitoring performed since December 2005 has demonstrated that the current groundwater pump-and-treat and re-injection system is controlling migration of the COCs and thus achieving the ROs. The metric for evaluating the remedial action will be to monitor changes in PCE concentrations in the Adams wells, Rhoades west well, the York well, QMW-7, QMW-8, QMW-10, and EW-5, which are located along the downgradient boundary of the plume.

Plume remediation and source control are not necessarily included in the remedial strategy. However, as previously discussed, the current remediation system may eventually remediate the defined “source” area within a reasonable timeframe. Due to the current size of the plume, plume remediation may be achieved using the current remediation system. However, several years may be required and plume remediation may be considered unnecessary once the “source” area is remediated and natural attenuation is capable of meeting the ROs.

3.3 DEFINITION OF REMEDIATION AREAS

The remediation area is divided into two sub-areas. The “plume” area includes groundwater impacted with dissolved PCE above the AWQS of 5.0 µg/L. The “source” area is defined as groundwater impacted with dissolved PCE above 50 µg/L. The boundaries of the “plume” area and “source” area based on the 2nd Quarter 2007 groundwater monitoring event are shown on

Figure 4. Extraction wells EW-1 through EW-4 are located within or near the “source” area and serve the purpose of controlling migration and reducing PCE concentrations within the “source” area. Extraction well EW-5 is located along the downgradient boundary of the “plume” area and serves the purpose of controlling migration of PCE at or near the AWQS of 5.0 µg/L. The majority of the contaminant mass removal and migration control is being performed by EW-3 and EW-4, which contain the highest PCE concentrations of the extraction wells and are currently set at the highest pumping rates. Re-injection of treated water at INJ-1 and INJ-2 has the effect of directing PCE impacted groundwater toward EW-3 and EW-4 and “flushing” PCE from both the saturated soil and groundwater, thus providing plume remediation to the south of the extraction wells.

3.4 ACHIEVEMENT OF REMEDIAL ACTION CRITERIA PURSUANT TO ARS §49-282.06

The RO’s established for the Site require that the selected remedy meet controlled migration, source control, monitoring, and possibly plume remediation. During the ERA evaluation, MACTEC and ADEQ evaluated three potential remedial alternatives for the Site; groundwater pump-and-treat, in-situ bioremediation, and monitored natural attenuation (MNA). Therefore, these remedial alternatives and possibly additional remedial alternatives were screened for effectiveness, implementability, cost, and ability to meet the RO’s.

The Remedial Alternative Screening (RAS) Technical Memorandum indicated that using a combination of remedial strategies and alternatives often has the effect of meeting the RO’s in a shorter timeframe and sometimes at a lower cost. Though in-situ bioremediation was proven effective by the treatability study, the cost to implement in-situ bioremediation as a source control technology was estimated to be higher than operating the pump-and-treat system for 10 years as a source control technology. The RAS indicated that in-situ chemical oxidation (ISCO), which uses chemical oxidants to degrade PCE to inert compounds, could possibly be effectively employed as a source control technology at a lower cost than operating the pump-and-treat system as a source control technology. ISCO was selected for further evaluation and in-situ bioremediation was added as a more aggressive remedial approach.

The FS evaluated four remedial approaches, including the reference remedy. They are listed as follows from more aggressive to less aggressive:

Remedial Alternative	Remedial Technology
More Aggressive Alternative 1	In-situ chemical oxidation (ISCO) as source control, pump-and-treat as controlled migration, and monitoring.
More Aggressive Alternative 2	In-situ bioremediation as source control, pump-and-treat as controlled migration, and monitoring.
Reference Remedy	Groundwater pump-and-treat as controlled migration
Less Aggressive	Monitored natural attenuation (MNA)

The groundwater pump-and-treat system had been installed and in operation at the time the FS was completed. It is operating effectively, is meeting the RO's, and has been shown to be cost effective. The FS identified pump-and-treat as the best alternative. Therefore, groundwater pump-and-treat as a controlled migration technology was selected as the reference technology. ISCO or in-situ bioremediation employed for source control, combined with pump-and-treat for controlled migration, were considered as more aggressive alternatives than groundwater pump-and-treat due to the linking of technologies and potential shorter timeframe for remediation. Both would employ the same pump-and-treat system currently at the site as part of its technology, but numerous additional wells would have to be installed to treat the entire plume and there would be potential site access issues. Though MNA alone will not immediately meet the RO's, MNA may be employed in the future, either as a stand alone approach, or in combination with pump-and-treat. Therefore, MNA was evaluated as a less aggressive alternative than groundwater pump-and-treat.

It is recommended that the Reference Remedy from the FS be selected as the Final Remedy for the Site. Based on comparison with the Less Aggressive and More Aggressive Remedies, the Reference Remedy appears to:

- Best assure the protection of public health and welfare and the environment;
- To the extent practicable, provide for the control, management, and cleanup of the PCE contamination, thus meeting the ROs for the Site; and,
- Is reasonable, necessary, cost-effective, and technically feasible.

Because the remediation system is currently operational and data indicates that it is controlling migration of the plume and is reducing PCE concentrations in the groundwater, this remedy is clearly the best choice. The results of groundwater modeling and review of operational data

suggests the system is reasonably efficient and that no significant changes other than adjustments of pumping rates are warranted in the near future. However, in the event the “source” area is remediated to PCE concentrations below 50 µg/L, the remediation system may be temporarily shut-down for a period of one year to evaluate if the less aggressive remedy of natural attenuation is capable of meeting the ROs. If natural attenuation is demonstrated to meet the ROs, then the remediation system may be removed and disconnected with ADEQ authorization and the natural attenuation remedy employed.

3.5 CONSISTENCY WITH TOWN OF QUARTZSITE WATER USE PLANS

The ROs were developed based on Town of Quartzsite water use plans. Therefore, the operation of the current remediation system is consistent with the Town of Quartzsite water use plans.

4.0 LIFE-CYCLE COSTS

MACTEC has completed an estimate of life-cycle costs for the design, installation, operation, maintenance, and monitoring for the remediation system. The remedial strategy for the remediation system is controlled migration. This is generally regarded as a long-term strategy. However, the system may remediate the “source” area to PCE concentrations below 50 µg/L and possibly the “plume” area to concentrations below 5.0 µg/L within the operational life-cycle of the system. The “source” area wells are currently identified as QMW-3, QMW-4, EW-3, and EW-4. Well EW-4 is located on the apparent edge of the “source” area. PCE concentrations in EW-4 have not changed significantly since December 2005, ranging from 39 µg/L to 55 µg/L and having an operational average of approximately 48 µg/L. PCE concentrations in QMW-3 have decreased approximately 107 µg/L since December 2005, which is an average of approximately 18 µg/L per quarter. PCE concentrations in well EW-3 have decreased approximately 38 µg/L since December 2005, which is an average of 6.0 µg/L per quarter. Applying the currently observed trends, the PCE concentrations in wells QMW-3, QMW-4, and EW-3 may be reduced below 50 µg/L within two years. However, the rate of PCE concentration decrease is expected to slow. Therefore, reduction of the PCE concentrations in wells QMW-3, QMW-4, and EW-3 below 50 µg/L could require more than five years.

There is more uncertainty regarding the timeframe required to reduce the PCE concentrations in all monitoring, remediation, and production wells to concentrations below 5.0 µg/L without rebound. With the exception of the Welcome RV Park well, QMW-1, and QMW-5, PCE concentrations in wells within the “plume” area and outside the “source” area have not changed significantly since startup of the remediation system in September 2005. The PCE concentration trends in the Welcome RV Park well, QMW-1, and QMW-5 indicate PCE concentrations in these wells may be below the AWQS of 5.0 µg/L within a few years. PCE concentrations are currently declining at rates of approximately 10 µg/L to 20 µg/L per year in the Welcome RV Park well, approximately 6.0 µg/L per year in QMW-1, and approximately 2.0 µg/L per year in QMW-5. However, these wells are located upgradient of the extraction wells and are influenced by the re-injection portion of the system. During operation of the remediation system, PCE concentrations in wells QMW-8 and QMW-10 have been decreasing. However, MACTEC anticipates the PCE concentrations in QMW-8 and QMW-10 should begin to decrease more appreciably after the “source” area is remediated below a PCE concentration of 50 µg/L.

In the FS, MACTEC evaluated costs for three potential system operation scenarios. For the purposes of providing a life-cycle cost estimate for the system, MACTEC is assuming a 30 year operation lifetime that includes a 19 year remediation system operation period (the system has been in operation for four years) followed by an eleven year monitoring period. The life-cycle cost estimate is also based on the following factors and assumptions:

- Groundwater extraction and re-injection rates will not change significantly over the operational lifespan of the remediation system;
- Additional injection wells are not required due to the rising water table. Specifically, should the re-injection rate to INJ-2 decrease due to the rising table, the re-injection rate to INJ-1 will be increased as appropriate to maintain the pumping rate. No additional remediation wells will be installed.
- System operation and maintenance (O&M) and groundwater monitoring will be performed as follows:
 - During the first four years of operation, which was from April 2003 to March 2007, the system O&M visits were performed once monthly and groundwater monitoring was conducted quarterly.
 - For the next five years of operation (June 2007 to June 2012), system O&M visits will continue to be performed once monthly, and groundwater monitoring will be conducted quarterly.
 - Assuming the source area has been remediated to PCE concentrations less than 50 µg/L, from June 2012 to June 2014 (years 10 and 11), the system O&M and monitoring program will not be changed.
 - From June 2014 to June 2021 (years 12 through 19), O&M visits will be reduced to once quarterly and the groundwater monitoring program will be reduced to bi-annual events. The program assumes no change in the number of wells that are sampled. The pump-and-treat system will be operated for this period or until monitoring indicates PCE concentrations have been reduced to below the AWQS of 5.0 µg/L in the wells currently included in the sampling program, whichever occurs first.
 - If PCE concentrations are still above the AWQS of 5.0 µg/L in some of the wells at the end of year 19 of operation, the pump-and-treat system will be shut down and a MNA program will be initiated. The current well network consists of 24 wells. The MNA program will involve only 10 of the wells and will be up to a five year program. Groundwater monitoring of the 10 wells will be performed quarterly for year 20, and bi-annually for years 21 through 30.
- A single GAC unit will be replaced once annually during system operation. The only capital equipment included with the remediation system are the groundwater pumps, controls, and the equalization tank. These items may require replacement. Pipes, hoses,

and gauges may require period repair/replacement. These items are considered standard maintenance items and are included in the cost estimate.

- Post closure tasks include abandonment of the monitoring and remediation wells by removing well vaults and filling the wells with grout, leaving subsurface piping in-place, and removing the surface equipment. The post-closure work is estimated to be completed between June 2032 and December 2032.
- The O&M and sampling costs have been assumed to increase on an inflationary basis of 5% per annum for the duration of the remedial action.

The estimate of the implementation cost of the final remedy does not include costs incurred during other ERA activities which are completed, such as the in-situ bioremediation treatability study and repairs to the Welcome RV Park well. The estimate of the total system implementation costs for the selected remedy includes:

- The cost for design and installation of the pilot test system from December 2002 through April 2003 was \$110,000.00 for the five month period.
- The cost for system monitoring, O&M, and reporting from April 2003 through April 2004 was \$80,000.00 for the 12 month period.
- The cost for design and installation of the full system from April 2004 through September 2005 was \$112,339.00 for the six month period.
- The cost for system monitoring, O&M, and reporting from April 2004 through June 2007 (does not include 2nd Quarter 2007 groundwater monitoring) was \$109,420.00 for the 26 month period.

Therefore, through June 2007, the total cost for design, installation, monitoring, and O&M of the system is \$411,759.00. Based on an assumed inflation rate of 5%, the following table presents the summary of the life-cycle cost analysis.

Summary of Life-Cycle Cost Analysis	
Operational Years	Estimated Cost
December 2002 – June 2007	\$411,759
June 2007 – June 2008	\$82,000
June 2008 – June 2009	\$74,558
June 2009 – June 2010	\$78,278
June 2010 – June 2011	\$82,191
June 2011 – June 2012	\$86,301
June 2012 – June 2013	\$90,616
June 2013 – June 2014	\$95,147
June 2014 – June 2015	\$61,000

Summary of Life-Cycle Cost Analysis	
Operational Years	Estimated Cost
June 2015 – June 2016	\$64,050
June 2016 – June 2017	\$67,253
June 2017 – June 2018	\$70,615
June 2018 – June 2019	\$74,146
June 2019 – June 2020	\$77,853
June 2020 – June 2021	\$81,746
June 2021 – June 2022	\$79,934
June 2022 – June 2023	\$43,000
June 2023 – June 2024	\$45,150
June 2024 – June 2025	\$47,408
June 2025 – June 2026	\$49,778
June 2026 – June 2027	\$52,267
June 2027 – June 2028	\$54,880
June 2028 – June 2029	\$57,624
June 2029 – June 2030	\$60,505
June 2030 – June 2031	\$63,531
June 2031 – June 2032	\$66,707
June 2032 – December 2032	\$80,000
Total Life-Cycle Cost	\$2,198,297.00

The costs include analytical testing, electrical power, equipment repair, GAC usage and other consumable supplies as part of O&M, and consulting and reporting.

5.0 DISPOSITION OF TREATED WATER

The pumped groundwater is treated using two GAC scrubbers. From April 2003 to September 2005, the treated water was re-injected at INJ-1 (see Figure 4). With startup of the full system in September 2005, the treated water was re-injected to both INJ-1 and INJ-2, with approximately 88% of the water re-injected at INJ-2. As described in Section 3.1.3, the system pumping rate may be adjusted in the future to optimize or increase the efficiency of the system. Adjustments and/or modifications to the system will be reported in periodic operation and monitoring reports.

One of the uncertainties associated with future operation of the system is the affect the rising water table will have on the re-injection rates, particularly at INJ-2. Should the re-injection rate at INJ-2 decrease significantly, modifications may be made to INJ-2 to optimize the injection rate or the re-injection rate to INJ-1 may be increased as appropriate and necessary. This may also be appropriate as the PCE concentrations in the monitoring wells upgradient of the extraction wells decrease. These wells are QMW-1, QMW-5, QMW-11, and the Welcome RV Park well.

6.0 CONCLUSIONS

Based on the information presented, the PRAP for the Site is to continue operation of the existing groundwater pump and treat and re-injection system at the current pumping rate of 7.5 to 8.5 gpm per the pumping schedule presented in Section 3.1.3. The pumping rates have recently stabilized to between 8.0 and 8.5 gpm. The system pumping rate may be adjusted in the future to optimize or increase the efficiency of the system. Modifications may also be made to the injection wells to optimize injection rates. Adjustments and/or modifications to the system will be reported in periodic operation and monitoring reports. Groundwater monitoring data since December 2005 indicate that the current system is operating as modeled and designed and is meeting the remedial strategy and achieving the ROs for the Site. System modifications may be performed in the future as water levels rise and dissolved PCE concentrations decrease. This may involve decreasing the re-injection rate at INJ-2 while increasing the re-injection rate and INJ-1. This may also involve the shut down of the pump-and-treat system to evaluate if monitored natural attenuation will be effective in meeting the remedial strategy and achieving the ROs. Should monitored natural attenuation be demonstrated to be effective in meeting the ROs, the pump-and-treat system will be dismantled; however, groundwater monitoring will continue until a time when ADEQ decides to remove the Site from the registry (see ARS 49-287.01 paragraph K).

REFERENCES

Arizona Administrative Code R18-16-406, R18-16-407 and R18-16-408

Arizona Department of Environmental Quality (ADEQ), 2003. “*Remedial Objectives Report, Tyson Wash WQARF Site, Quartzsite, Arizona*” dated May 14, 2003

Arizona Revised Statutes §49-281 et. seq.

Environmental Protection Agency (EPA), 1988. “*Guidance for Conducting Remedial Investigations and Feasibility Studies Under CERCLA, Interim Final*” dated October 1988.

MACTEC, 2003. “*Remedial Investigation Report, Tyson Wash WQARF Site, Quartzsite, Arizona*” prepared by MACTEC for ADEQ and dated June 30, 2003

MACTEC, 2007. “*Feasibility Study Report, Tyson Wash WQARF Site, Quartzsite, Arizona*” prepared by MACTEC for ADEQ and dated June 23, 2007

FIGURES

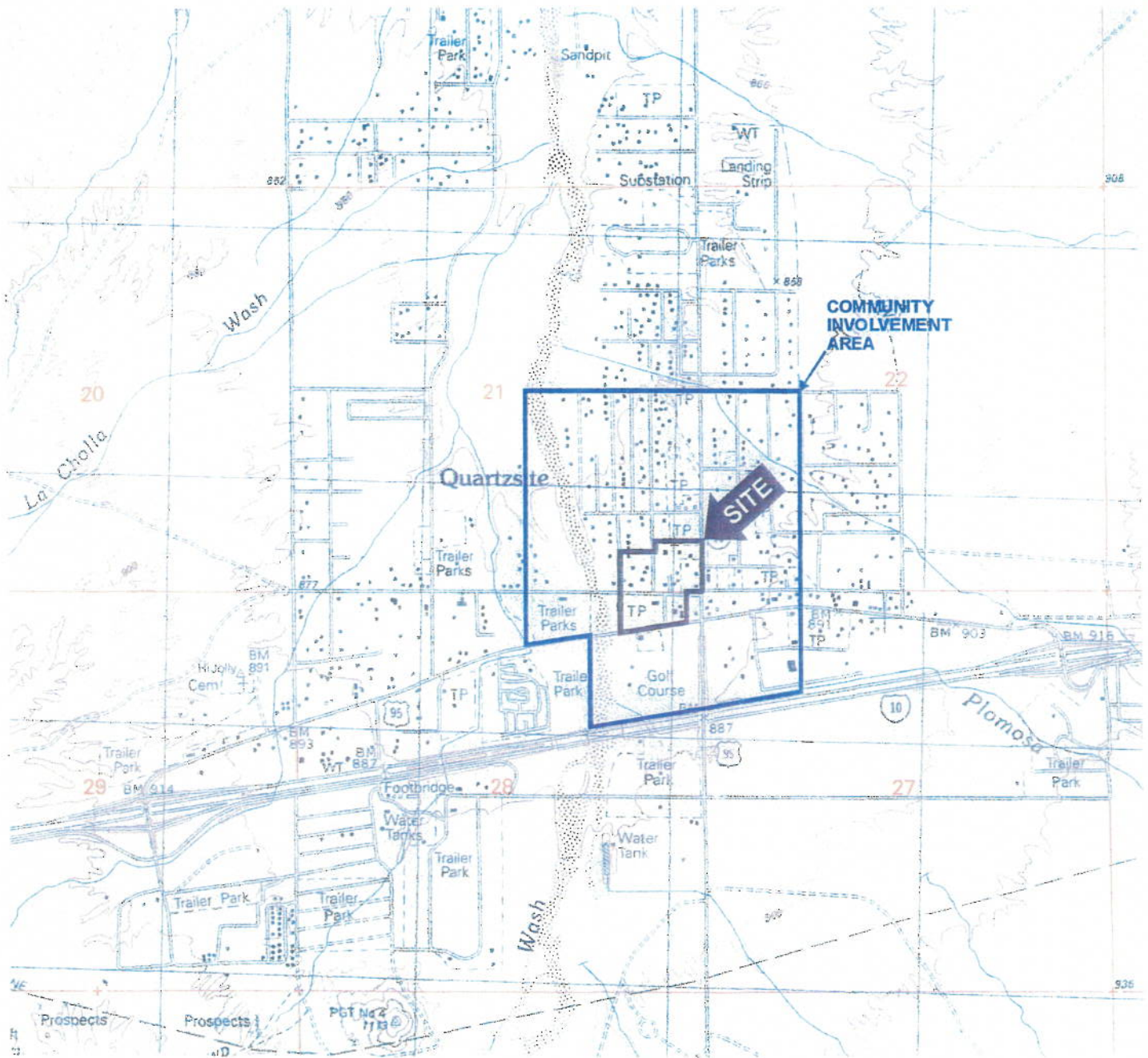

NOTE:

MAP TAKEN FROM QUARTZSITE, ARIZONA
U.S. GEOLOGICAL SURVEY 7.5 MINUTE
TOPOGRAPHIC MAP.



SITE LOCATION
ADEQ TYSON WASH WQARF SITE
QUARTZSITE, ARIZONA

FIGURE

1

DRAWN
DANIEL L. KUDLICKI

PROJECT NUMBER
661026

APPROVED
SAW

DATE
7/12/2001

Figure 2
Groundwater Elevation vs Time, May 2000 - May 2007
Tyson Wash WQARF Site

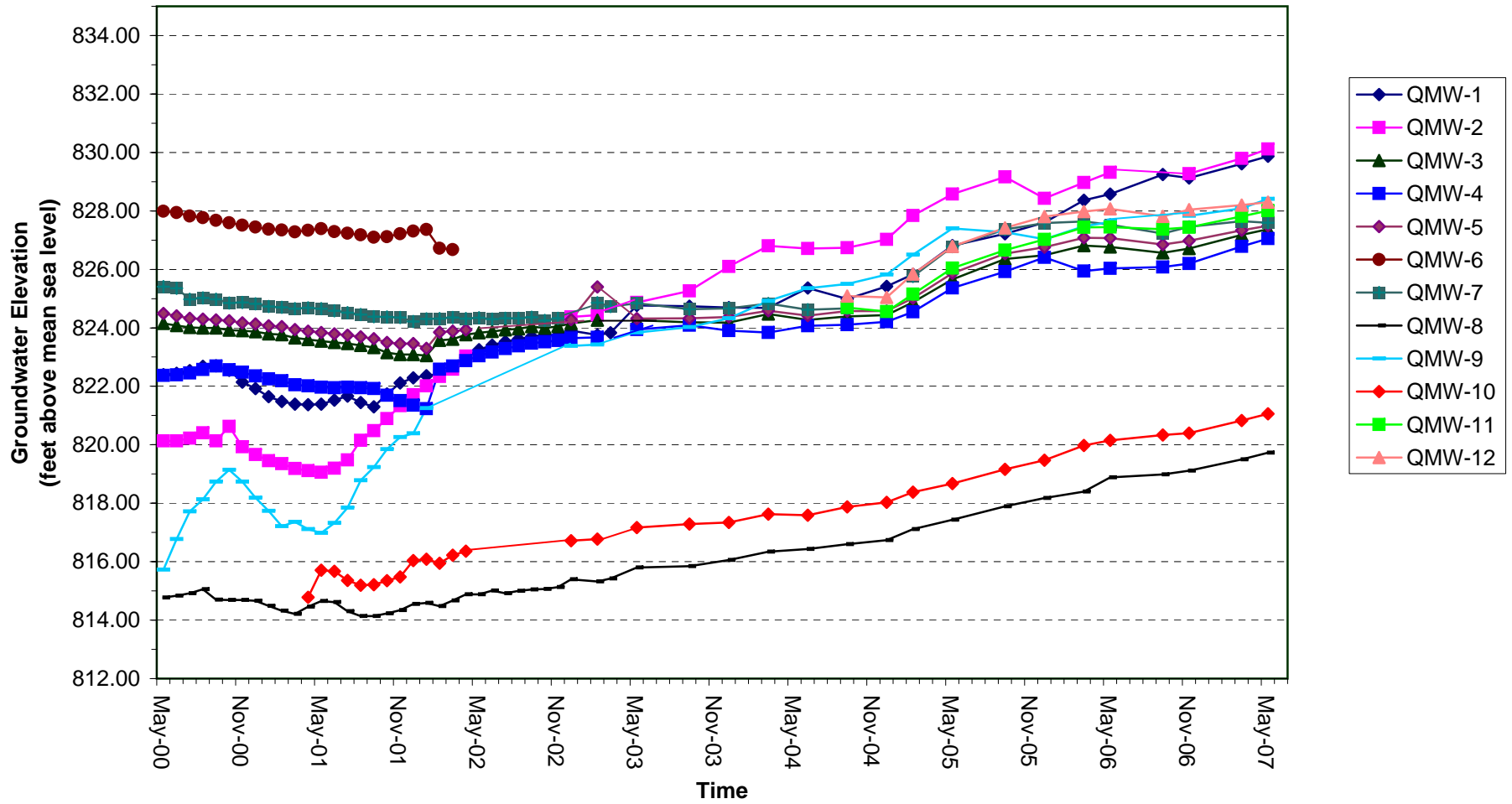

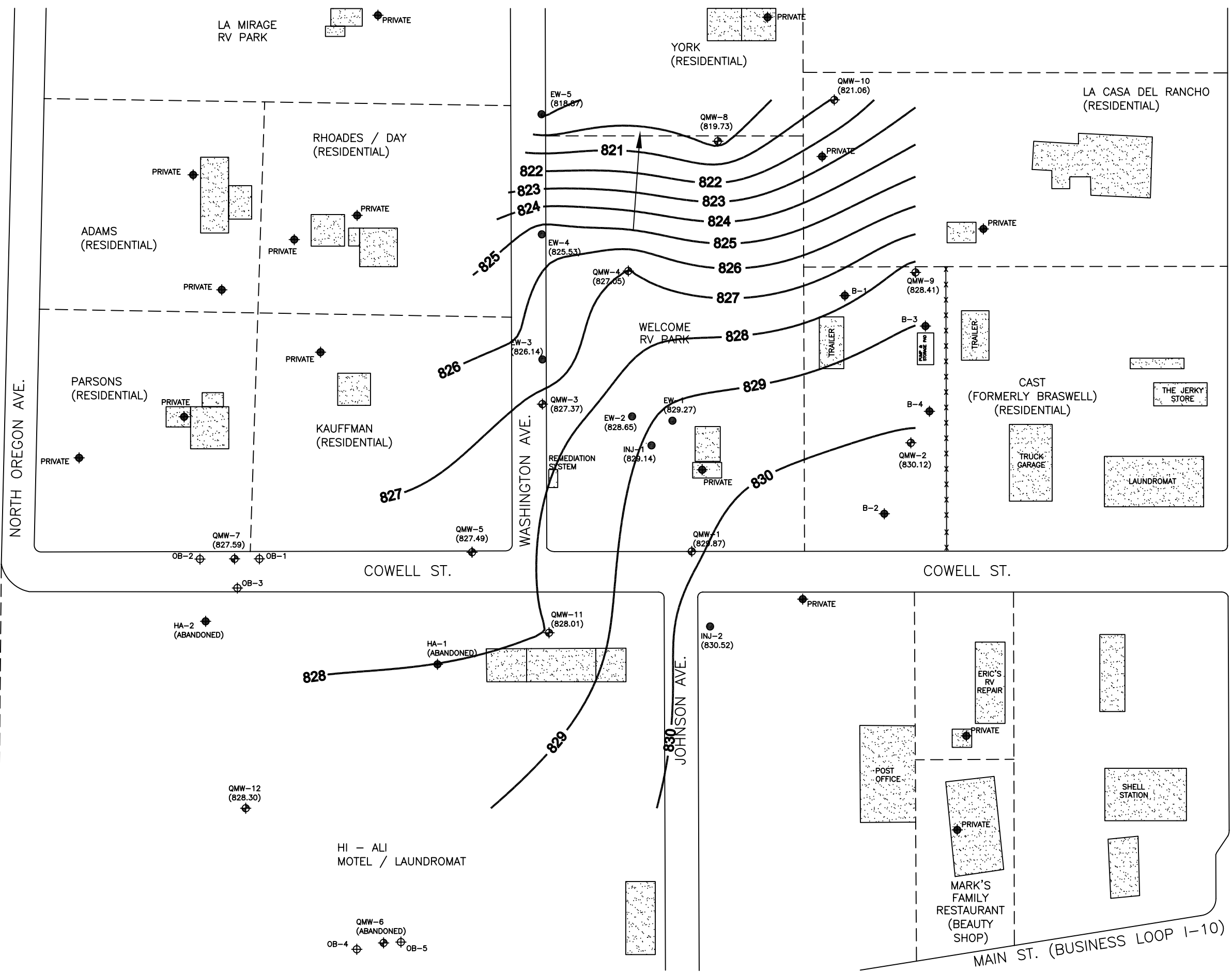

- EXPLANATION**
- QMW-2 ◈ MONITORING WELL
 - QMW-2 ⊕ OBSERVATION WELL
 - B-4 ◈ DOMESTIC WELL
 - GROUNDWATER CONTOUR LINE
- - - DASHED WHERE INFERRED
 - ← GROUNDWATER FLOW DIRECTION
 - EW-1 ● WATER TREATMENT EXTRACTION AND INJECTION WELLS
- NOTE: LOCATION & NUMBER OF DOMESTIC WELLS ARE APPROXIMATE.

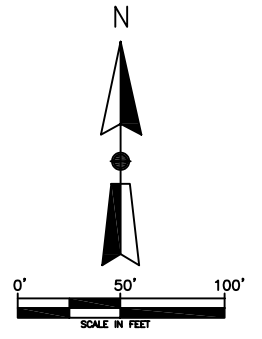

CENTRAL BLVD. (US-95)

NORTH OREGON AVE.

COWELL ST.

COWELL ST.

COWELL ST.

JOHNSON AVE.

MAIN ST. (BUSINESS LOOP 1-10)



3630 E. WIER AVE.; PHOENIX, ARIZONA 85040

MAY 17, 2007
GROUNDWATER ELEVATIONS

SITE LOCATION: ADEQ TYSON WASH WQARF SITE QUARTZSITE, ARIZONA	
DRAWN	PROJECT NO. APPROVED DATE FIGURE
4972-07-2100.6.0	07/19/07 3

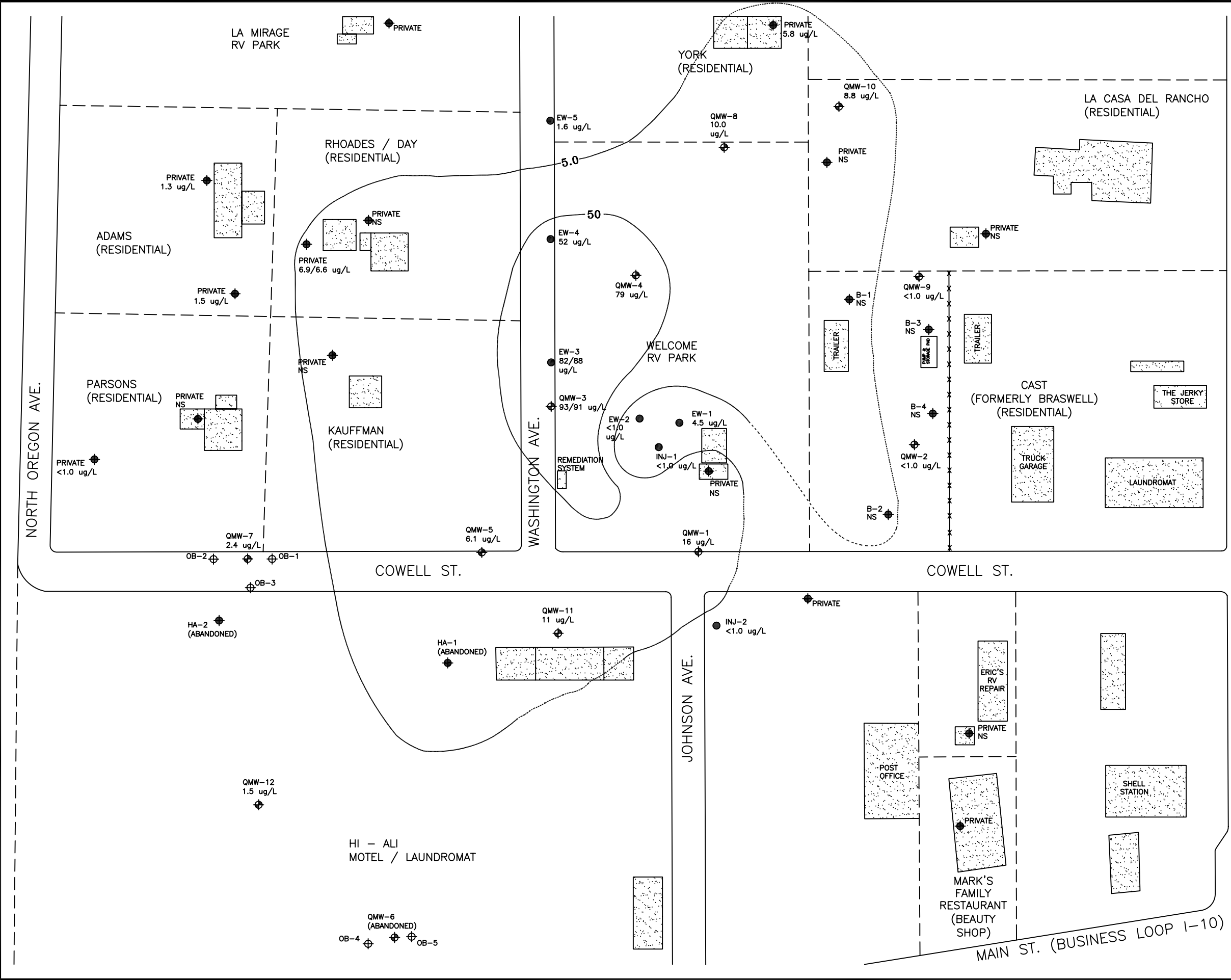

EXPLANATION

- QMW-2 MONITORING WELL
- QMW-2 OBSERVATION WELL
- B-4 DOMESTIC WELL
- EW-1 WATER TREATMENT EXTRACTION AND INJECTION WELLS
- NS NOT SAMPLED

NOTE:

- APPROX. PCE ISOCONCENTRATION LINE DASHED WHERE INFERRED
- LOCATION & NUMBER OF DOMESTIC WELLS ARE APPROXIMATE.

PCE CONCENTRATIONS SHOWN IN MICROGRAMS PER LITER (ug/L)

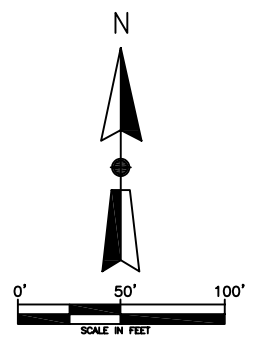

CENTRAL BLVD. (US-95)

3630 E. WIER AVE.; PHOENIX, ARIZONA 85040				
PCE CONCENTRATIONS 2ND QUARTER 2007				
SITE LOCATION:		ADEQ TYSON WASH WQARF SITE QUARTZSITE, ARIZONA		
DRAWN	PROJECT NO.	APPROVED	DATE	FIGURE
	4972-07-2100.6.0		07/19/07	4

TABLES

**Table 1. Results of Depth to Groundwater Measurements, May 2000 - March 2006
Tyson Wash WQARF Site, Quartzsite, Arizona**

WELL ID (ADWR Registration Number)	Date Measured	Well Screened Interval (ft)	Depth To Groundwater (ft below Measuring Pt)	Measuring Point Elevation (ft above MSL)	Groundwater Table Elevation (ft above MSL)
QMW-1 (55-561847) 56370	05/11/00	30-80	45.79	868.28	822.49
	06/11/00	30-80	45.84	868.28	822.44
	07/11/00	30-80	45.74	868.28	822.54
	08/11/00	30-80	45.60	868.28	822.68
	09/11/00	30-80	45.58	868.28	822.70
	10/11/00	30-80	45.73	868.28	822.55
	11/11/00	30-80	46.14	868.28	822.14
	12/11/00	30-80	46.36	868.28	821.92
	01/11/01	30-80	46.63	868.28	821.65
	02/11/01	30-80	46.80	868.28	821.48
	03/11/01	30-80	46.89	868.28	821.39
	04/11/01	30-80	46.91	868.28	821.37
	05/11/01	30-80	46.89	868.28	821.39
	06/11/01	30-80	46.75	868.28	821.53
	07/11/01	30-80	46.62	868.28	821.66
	08/11/01	30-80	46.84	868.28	821.44
	09/11/01	30-80	46.97	868.28	821.31
	10/11/01	30-80	46.54	868.28	821.74
	11/11/01	30-80	46.17	868.28	822.11
	12/11/01	30-80	45.99	868.28	822.29
	01/11/02	30-80	45.92	868.28	822.36
	02/11/02	30-80	45.85	868.28	822.43
	03/11/02	30-80	45.63	868.28	822.65
	04/11/02	30-80	45.29	868.28	822.99
	05/11/02	30-80	45.03	868.28	823.25
	06/11/02	30-80	44.87	868.28	823.41
	07/11/02	30-80	44.75	868.28	823.53
	08/11/02	30-80	44.66	868.28	823.62
	09/11/02	30-80	44.58	868.28	823.70
	10/11/02	30-80	44.52	868.28	823.76
	11/11/02	30-80	44.53	868.28	823.75
	12/12/02 ¹	30-80	44.38	868.28	823.90
	02/18/03 ¹	30-80	44.52	868.28	823.76
	03/11/03	30-80	44.45	868.28	823.83
	05/14/03 ¹	30-80	43.51	868.28	824.77
	09/04/03 ¹	30-80	43.54	868.28	824.74
	12/03/03 ¹	30-80	43.59	868.28	824.69
	03/03/04 ¹	30-80	43.60	868.28	824.68
	06/08/04 ³	30-80	42.92	868.28	825.36
	09/23/04 ³	30-80	43.29	868.28	824.99
	12/07/04 ³	30-80	42.86	868.28	825.42
	02/16/05 ³	30-80	42.45	868.28	825.83
	05/25/05 ³	30-80	41.47	868.28	826.81
09/20/05 ³	30-80	41.06	868.28	827.22	
12/6/05 ^{3,5}	30-80	40.66	868.28	827.62	
12/7/05 ³	30-80	40.68	868.28	827.60	
2/28/06 ^{3,5}	30-80	39.91	868.28	828.37	
3/1/06 ³	30-80	39.92	868.28	828.36	
5/22/06 ^{3,5}	30-80	39.71	868.28	828.57	
5/23/06 ³	30-80	39.70	868.28	828.58	
9/12/06 ^{3,5}	30-80	38.99	868.28	829.29	
9/14/06 ³	30-80	39.03	868.28	829.25	
11/28/06 ^{3,5}	30-80	38.94	868.28	829.34	
11/29/06 ³	30-80	39.15	868.28	829.13	
2/27/07 ^{3,5}	30-80	38.34	868.28	829.94	
3/1/07 ³	30-80	38.67	868.28	829.61	
5/15/07 ^{3,5}	30-80	38.20	868.28	830.08	
5/17/07 ³	30-80	38.41	868.28	829.87	
QMW-2 (55-561849) 56371	05/11/00	30-80	50.14	870.27	820.13
	06/11/00	30-80	50.14	870.27	820.13
	07/11/00	30-80	50.05	870.27	820.22
	08/11/00	30-80	49.86	870.27	820.41
	09/11/00	30-80	50.14	870.27	820.13
	10/11/00	30-80	49.64	870.27	820.63
	11/11/00	30-80	50.34	870.27	819.93
	12/11/00	30-80	50.61	870.27	819.66
	01/11/01	30-80	50.82	870.27	819.45
	02/11/01	30-80	50.92	870.27	819.35
	03/11/01	30-80	51.08	870.27	819.19
04/11/01	30-80	51.16	870.27	819.11	

See Page 11 for Notes

**Table 1. Results of Depth to Groundwater Measurements, May 2000 - March 2006
Tyson Wash WQARF Site, Quartzsite, Arizona**

WELL ID (ADWR Registration Number)	Date Measured	Well Screened Interval (ft)	Depth To Groundwater (ft below Measuring Pt)	Measuring Point Elevation (ft above MSL)	Groundwater Table Elevation (ft above MSL)
QMW-2 (55-561849) 56371	05/11/01	30-80	51.21	870.27	819.06
	06/11/01	30-80	51.07	870.27	819.20
	08/11/01	30-80	50.12	870.27	820.15
	09/11/01	30-80	49.79	870.27	820.48
	10/11/01	30-80	49.38	870.27	820.89
	11/11/01	30-80	48.94	870.27	821.33
	12/11/01	30-80	48.56	870.27	821.71
	01/11/02	30-80	48.26	870.27	822.01
	02/11/02	30-80	47.94	870.27	822.33
	03/11/02	30-80	47.69	870.27	822.58
	04/11/02	30-80	47.24	870.27	823.03
	12/12/02 ¹	30-80	45.90	870.27	824.37
	02/12/03 ¹	30-80	45.83	870.27	824.44
	05/14/03 ¹	30-80	45.40	870.27	824.87
	09/04/03 ¹	30-80	45.01	870.27	825.26
	12/04/03 ¹	30-80	44.17	870.27	826.10
	03/03/04 ¹	30-80	43.47	870.27	826.80
	06/09/04 ³	30-80	43.56	870.27	826.71
	9/22/04 ³	30-80	43.53	870.27	826.74
	12/08/04 ³	30-80	43.25	870.27	827.02
	02/16/05 ³	30-80	42.43	870.27	827.84
	05/25/05 ³	30-80	41.69	870.27	828.58
	10/3/05 ³	30-80	41.11	870.27	829.16
	12/7/05 ³	30-80	41.84	870.27	828.43
	3/1/06 ³	30-80	41.30	870.27	828.97
	5/23/06 ³	30-80	40.95	870.27	829.32
	9/14/06 ³	30-80	Inaccessible	870.27	NM
11/28/06 ³	30-80	41.00	870.27	829.27	
3/1/07 ³	30-80	40.47	870.27	829.80	
5/17/07 ³	30-80	40.15	870.27	830.12	
QMW-3 (55-561848) 56372	05/11/00	30-80	43.54	867.69	824.15
	06/11/00	30-80	43.61	867.69	824.08
	07/11/00	30-80	43.68	867.69	824.01
	08/11/00	30-80	43.69	867.69	824.00
	09/11/00	30-80	43.69	867.69	824.00
	10/11/00	30-80	43.77	867.69	823.92
	11/11/00	30-80	43.79	867.69	823.90
	12/11/00	30-80	43.82	867.69	823.87
	01/11/01	30-80	43.90	867.69	823.79
	02/11/01	30-80	43.92	867.69	823.77
	03/11/01	30-80	44.03	867.69	823.66
	04/11/01	30-80	44.09	867.69	823.60
	05/11/01	30-80	44.14	867.69	823.55
	06/11/01	30-80	44.19	867.69	823.50
	07/11/01	30-80	44.23	867.69	823.46
	08/11/01	30-80	44.29	867.69	823.40
	09/11/01	30-80	44.36	867.69	823.33
	10/11/01	30-80	44.24	867.69	823.45
	11/11/01	30-80	44.18	867.69	823.51
	12/11/01	30-80	44.19	867.69	823.50
	01/11/02	30-80	44.14	867.69	823.55
	02/11/02	30-80	44.12	867.69	823.57
	03/11/02	30-80	44.08	867.69	823.61
	04/11/02	30-80	43.92	867.69	823.77
	05/11/02	30-80	43.86	867.69	823.83
	06/11/02	30-80	43.81	867.69	823.88
	07/11/02	30-80	43.76	867.69	823.93
08/11/02	30-80	43.72	867.69	823.97	
09/11/02	30-80	43.65	867.69	824.04	
10/11/02	30-80	43.69	867.69	824.00	
11/11/02	30-80	43.64	867.69	824.05	
12/12/02	30-80	43.54	867.69	824.15	
02/18/03 ¹	30-80	43.43	867.69	824.26	
05/14/03 ¹	30-80	43.64	867.69	824.05	
09/04/03 ¹	30-80	43.50	867.69	824.19	

See Page 11 for Notes

**Table 1. Results of Depth to Groundwater Measurements, May 2000 - March 2006
Tyson Wash WQARF Site, Quartzsite, Arizona**

WELL ID (ADWR Registration Number)	Date Measured	Well Screened Interval (ft)	Depth To Groundwater (ft below Measuring Pt)	Measuring Point Elevation (ft above MSL)	Groundwater Table Elevation (ft above MSL)
QMW-3 (55-561848) 56372	12/03/03 ¹	30-80	43.51	867.69	824.18
	03/03/04 ¹	30-80	43.22	867.69	824.47
	06/08/04 ³	30-80	43.42	867.69	824.27
	12/07/04 ³	30-80	43.25	867.69	824.44
	02/16/05 ³	30-80	42.81	867.69	824.88
	05/25/05 ³	30-80	42.03	867.69	825.66
	9/20/05 ³	30-80	41.34	867.69	826.35
	12/6/05 ^{3,5}	30-80	41.49	867.69	826.20
	12/7/05 ³	30-80	41.21	867.69	826.48
	2/28/06 ^{3,5}	30-80	41.04	867.69	826.65
	3/1/06 ³	30-80	40.88	867.69	826.81
	5/22/06 ^{3,5}	30-80	41.28	867.69	826.41
	5/23/06 ³	30-80	40.92	867.69	826.77
	9/12/06 ^{3,5}	30-80	41.61	867.69	826.08
	9/14/06 ³	30-80	41.12	867.69	826.57
	11/28/06 ^{3,5}	30-80	41.34	867.69	826.35
	11/29/06 ³	30-80	40.98	867.69	826.71
	2/27/07 ^{3,5}	30-80	40.83	867.69	826.86
3/1/07 ³	30-80	40.51	867.69	827.18	
5/15/07 ^{3,5}	30-80	40.71	867.69	826.98	
5/17/07 ³	30-80	40.32	867.69	827.37	
QMW-4 (55-567650) 57292	05/11/00	30-60	45.73	867.59	821.86
	06/11/00	30-60	45.71	867.59	821.88
	07/11/00	30-60	45.65	867.59	821.94
	08/11/00	30-60	45.53	867.59	822.06
	09/11/00	30-60	44.90	867.59	822.69
	10/11/00	30-60	45.03	867.59	822.56
	11/11/00	30-60	45.62	867.59	821.97
	12/11/00	30-60	45.75	867.59	821.84
	01/11/01	30-60	45.85	867.59	821.74
	02/11/01	30-60	45.91	867.59	821.68
	03/11/01	30-60	46.05	867.59	821.54
	04/11/01	30-60	46.09	867.59	821.50
	05/11/01	30-60	46.13	867.59	821.46
	06/11/01	30-60	46.15	867.59	821.44
	07/11/01	30-60	46.15	867.59	821.44
	08/11/01	30-60	46.15	867.59	821.44
	09/11/01	30-60	46.18	867.59	821.41
	10/11/01	30-60	46.41	867.59	821.18
	11/11/01	30-60	46.59	867.59	821.00
	12/11/01	30-60	46.75	867.59	820.84
	01/11/02	30-60	46.87	867.59	820.72
	02/11/02	30-60	45.52	867.59	822.07
	03/11/02	30-60	45.41	867.59	822.18
	04/11/02	30-60	45.22	867.59	822.37
	05/11/02	30-60	45.06	867.59	822.53
	06/11/02	30-60	44.93	867.59	822.66
	07/11/02	30-60	44.81	867.59	822.78
	08/11/02	30-60	44.72	867.59	822.87
	09/11/02	30-60	44.63	867.59	822.96
	10/11/02	30-60	44.58	867.59	823.01
	11/11/02	30-60	44.54	867.59	823.05
	12/12/02 ¹	30-60	44.45	867.59	823.14
	02/12/03 ¹	30-60	44.43	867.59	823.16
05/14/03 ¹	30-60	44.16	867.59	823.43	
09/04/03 ¹	30-60	44.01	867.59	823.58	
12/03/03 ¹	30-60	44.20	867.59	823.39	
03/03/04 ¹	30-60	43.75	867.59	823.84	
06/08/04 ³	30-60	43.52	867.59	824.07	
09/23/04 ³	30-60	43.48	867.59	824.11	
12/08/04 ³	30-60	43.38	867.59	824.21	
02/17/05 ³	30-60	43.04	867.59	824.55	
05/25/05 ³	30-60	42.23	867.59	825.36	

See Page 11 for Notes

**Table 1. Results of Depth to Groundwater Measurements, May 2000 - March 2006
Tyson Wash WQARF Site, Quartzsite, Arizona**

WELL ID (ADWR Registration Number)	Date Measured	Well Screened Interval (ft)	Depth To Groundwater (ft below Measuring Pt)	Measuring Point Elevation (ft above MSL)	Groundwater Table Elevation (ft above MSL)
QMW-4 (55-567650) 57292	09/20/05 ³	30-60	41.67	867.59	825.92
	12/6/05 ^{3,5}	30-60	42.14	867.59	825.45
	12/7/05 ³	30-60	41.18	867.59	826.41
	2/28/06 ^{3,5}	30-60	41.67	867.59	825.92
	3/1/06 ³	30-60	41.65	867.59	825.94
	5/23/06 ³	30-60	41.56	867.59	826.03
	9/12/06 ^{3,5}	30-60	41.57	867.59	826.02
	9/14/06 ³	30-60	41.51	867.59	826.08
	11/28/06 ^{3,5}	30-60	41.33	867.59	826.26
	11/29/06 ³	30-60	41.39	867.59	826.20
	2/27/07 ^{3,5}	30-60	40.75	867.59	826.84
	3/1/07 ³	30-60	40.80	867.59	826.79
	5/15/07 ^{3,5}	30-60	40.61	867.59	826.98
	5/17/07 ³	30-60	40.54	867.59	827.05
QMW-5 (55-567649) 57293	05/11/00	35-65	42.56	867.05	824.49
	06/11/00	35-65	42.64	867.05	824.41
	07/11/00	35-65	42.72	867.05	824.33
	08/11/00	35-65	42.75	867.05	824.30
	09/11/00	35-65	42.78	867.05	824.27
	10/11/00	35-65	42.81	867.05	824.24
	11/11/00	35-65	42.88	867.05	824.17
	12/11/00	35-65	42.92	867.05	824.13
	01/11/01	35-65	42.98	867.05	824.07
	02/11/01	35-65	43.01	867.05	824.04
	03/11/01	35-65	43.11	867.05	823.94
	04/11/01	35-65	43.16	867.05	823.89
	05/11/01	35-65	43.21	867.05	823.84
	06/11/01	35-65	43.26	867.05	823.79
	07/11/01	35-65	43.30	867.05	823.75
	08/11/01	35-65	43.36	867.05	823.69
	09/11/01	35-65	43.42	867.05	823.63
	10/11/01	35-65	43.35	867.05	823.70
	11/11/01	35-65	43.32	867.05	823.73
	12/11/01	35-65	43.31	867.05	823.74
	01/11/02	35-65	43.13	867.05	823.92
	02/11/02	35-65	43.20	867.05	823.85
	03/11/02	35-65	43.16	867.05	823.89
	04/11/02	35-65	43.12	867.05	823.93
	12/12/02 ¹	35-65	42.77	867.05	824.28
	02/18/03 ¹	35-65	41.65	867.05	825.40
	05/14/03 ¹	35-65	42.73	867.05	824.32
	09/04/03 ¹	35-65	42.72	867.05	824.33
	12/03/03 ¹	35-65	42.68	867.05	824.37
	03/04/04 ¹	35-65	42.47	867.05	824.58
	06/08/04 ³	35-65	42.63	867.05	824.42
	09/23/04 ³	35-65	42.48	867.05	824.57
	12/07/04 ³	35-65	42.48	867.05	824.57
	02/16/05 ³	35-65	42.04	867.05	825.01
	05/25/05 ³	35-65	41.18	867.05	825.87
	09/20/05 ³	35-65	40.51	867.05	826.54
	12/6/05 ^{3,5}	35-65	40.30	867.05	826.75
	12/7/05 ³	35-65	40.29	867.05	826.76
	2/28/06 ^{3,5}	35-65	39.98	867.05	827.07
	3/1/06 ³	35-65	39.97	867.05	827.08
5/22/06 ^{3,5}	35-65	40.03	867.05	827.02	
5/23/06 ³	35-65	39.98	867.05	827.07	
9/12/06 ^{3,5}	35-65	40.28	867.05	826.77	
9/14/06 ³	35-65	40.20	867.05	826.85	
11/28/06 ^{3,5}	35-65	40.05	867.05	827.00	
11/29/06 ³	35-65	40.07	867.05	826.98	
2/27/07 ^{3,5}	35-65	39.67	867.05	827.38	
3/1/07 ³	35-65	39.71	867.05	827.34	
5/15/07 ^{3,5}	35-65	39.60	867.05	827.45	
5/17/07 ³	35-65	39.56	867.05	827.49	

See Page 11 for Notes

**Table 1. Results of Depth to Groundwater Measurements, May 2000 - March 2006
Tyson Wash WQARF Site, Quartzsite, Arizona**

WELL ID (ADWR Registration Number)	Date Measured	Well Screened Interval (ft)	Depth To Groundwater (ft below Measuring Pt)	Measuring Point Elevation (ft above MSL)	Groundwater Table Elevation (ft above MSL)
QMW-6 (55-578364)	05/11/00	35-70	42.29	870.28	827.99
	06/11/00	35-70	42.34	870.28	827.94
	07/11/00	35-70	42.46	870.28	827.82
	08/11/00	35-70	42.51	870.28	827.77
	09/11/00	35-70	42.60	870.28	827.68
	10/11/00	35-70	42.69	870.28	827.59
	11/11/00	35-70	42.77	870.28	827.51
	12/11/00	35-70	42.83	870.28	827.45
	01/11/01	35-70	42.91	870.28	827.37
	02/11/01	35-70	42.93	870.28	827.35
	04/11/01	35-70	42.94	870.28	827.34
	05/11/01	35-70	42.89	870.28	827.39
	06/11/01	35-70	42.99	870.28	827.29
	07/11/01	35-70	43.04	870.28	827.24
	08/11/01	35-70	43.10	870.28	827.18
	09/11/01	35-70	43.18	870.28	827.10
	10/11/01	35-70	43.25	870.28	827.03
	11/11/01	35-70	43.37	870.28	826.91
	12/11/01	35-70	43.45	870.28	826.83
	01/11/02	35-70	43.50	870.28	826.78
02/11/02	35-70	43.56	870.28	826.72	
03/11/02	35-70	43.60	870.28	826.68	
QMW-7 (55-577300) 58691	05/11/00	35-70	41.34	866.75	825.41
	06/11/00	35-70	41.40	866.75	825.35
	07/11/00	35-70	41.77	866.75	824.98
	08/11/00	35-70	41.73	866.75	825.02
	09/11/00	35-70	41.77	866.75	824.98
	10/11/00	35-70	41.90	866.75	824.85
	11/11/00	35-70	41.88	866.75	824.87
	12/11/00	35-70	41.93	866.75	824.82
	01/11/01	35-70	42.02	866.75	824.73
	02/11/01	35-70	42.05	866.75	824.70
	03/11/01	35-70	42.09	866.75	824.66
	04/11/01	35-70	42.07	866.75	824.68
	05/11/01	35-70	42.09	866.75	824.66
	06/11/01	35-70	42.17	866.75	824.58
	07/11/01	35-70	42.23	866.75	824.52
	08/11/01	35-70	42.30	866.75	824.45
	09/11/01	35-70	42.37	866.75	824.38
	10/11/01	35-70	42.38	866.75	824.37
	11/11/01	35-70	42.40	866.75	824.35
	12/11/01	35-70	42.53	866.75	824.22
	01/11/02	35-70	42.44	866.75	824.31
	02/11/02	35-70	42.43	866.75	824.32
	03/11/02	35-70	42.40	866.75	824.35
	04/11/02	35-70	42.43	866.75	824.32
	05/11/02	35-70	42.41	866.75	824.34
	06/11/02	35-70	42.45	866.75	824.30
	07/11/02	35-70	42.42	866.75	824.33
	08/11/02	35-70	42.42	866.75	824.33
	09/11/02	35-70	42.39	866.75	824.36
	10/11/02	35-70	42.50	866.75	824.25
	11/11/02	35-70	42.42	866.75	824.33
	12/12/02	35-70	NM	866.75	--
02/18/03 ¹	35-70	41.89	866.75	824.86	
05/14/03 ¹	35-70	41.91	866.75	824.84	
09/04/03 ¹	35-70	42.11	866.75	824.64	
12/03/03 ¹	35-70	42.08	866.75	824.67	
03/04/04 ¹	35-70	41.92	866.75	824.83	
06/08/04 ³	35-70	42.13	866.75	824.62	
09/23/04 ³	35-70	42.08	866.75	824.67	
12/07/04 ⁴	35-70	NM	866.75	--	
02/16/05 ³	35-70	40.99	866.75	825.76	
05/25/05 ³	35-70	39.97	866.75	826.78	

See Page 11 for Notes

**Table 1. Results of Depth to Groundwater Measurements, May 2000 - March 2006
Tyson Wash WQARF Site, Quartzsite, Arizona**

WELL ID (ADWR Registration Number)	Date Measured	Well Screened Interval (ft)	Depth To Groundwater (ft below Measuring Pt)	Measuring Point Elevation (ft above MSL)	Groundwater Table Elevation (ft above MSL)
QMW-7 (55-577300) 58691	9/20/05 ³	35-70	39.39	866.75	827.36
	12/7/05 ³	35-70	39.17	866.75	827.58
	3/1/06 ³	35-70	39.11	866.75	827.64
	5/23/06 ³	35-70	39.22	866.75	827.53
	9/14/06 ³	35-70	39.52	866.75	827.23
	11/29/06 ³	35-70	39.29	866.75	827.46
	3/1/07 ³	35-70	39.10	866.75	827.65
	5/17/07 ³	35-70	39.16	866.75	827.59
QMW-8 (55-577298) 58692	05/11/00	35-75	52.44	867.21	814.77
	06/11/00	35-75	52.37	867.21	814.84
	07/11/00	35-75	52.29	867.21	814.92
	09/11/00	35-75	52.51	867.21	814.70
	10/11/00	35-75	52.52	867.21	814.69
	11/11/00	35-75	52.52	867.21	814.69
	12/11/00	35-75	52.55	867.21	814.66
	01/11/01	35-75	52.72	867.21	814.49
	02/11/01	35-75	52.89	867.21	814.32
	03/11/01	35-75	53.00	867.21	814.21
	04/11/01	35-75	52.75	867.21	814.46
	05/11/01	35-75	52.56	867.21	814.65
	06/11/01	35-75	52.59	867.21	814.62
	07/11/01	35-75	52.91	867.21	814.30
	08/11/01	35-75	53.07	867.21	814.14
	09/11/01	35-75	53.07	867.21	814.14
	10/11/01	35-75	52.98	867.21	814.23
	11/11/01	35-75	52.87	867.21	814.34
	12/11/01	35-75	52.66	867.21	814.55
	01/11/02	35-75	52.62	867.21	814.59
	02/11/02	35-75	52.73	867.21	814.48
	03/11/02	35-75	52.54	867.21	814.67
	04/11/02	35-75	52.33	867.21	814.88
	05/11/02	35-75	52.33	867.21	814.88
	06/11/02	35-75	52.20	867.21	815.01
	07/11/02	35-75	52.29	867.21	814.92
	08/11/02	35-75	52.21	867.21	815.00
	09/11/02	35-75	52.16	867.21	815.05
	10/11/02	35-75	52.14	867.21	815.07
	11/11/02	35-75	52.08	867.21	815.13
	12/12/02	35-75	51.97	867.21	815.24
	02/12/03	35-75	51.89	867.21	815.32
	05/14/03 ¹	35-75	51.41	867.21	815.80
	09/04/03 ¹	35-75	51.36	867.21	815.85
	12/03/03 ¹	35-75	51.15	867.21	816.06
03/03/04 ¹	35-75	50.87	867.21	816.34	
06/08/04 ³	35-75	50.78	867.21	816.43	
09/23/04 ³	35-75	50.61	867.21	816.60	
12/08/04 ³	35-75	50.47	867.21	816.74	
02/17/05 ³	35-75	50.10	867.21	817.11	
05/25/05 ³	35-75	49.78	867.21	817.43	
09/20/05 ³	35-75	49.32	867.21	817.89	
12/6/05 ^{3,5}	35-75	49.03	867.21	818.18	
12/7/05 ³	35-75	49.03	867.21	818.18	
2/28/06 ^{3,5}	35-75	48.60	867.21	818.61	
3/1/06 ³	35-75	48.81	867.21	818.40	
5/22/06 ^{3,5}	35-75	48.36	867.21	818.85	
5/23/06 ³	35-75	48.33	867.21	818.88	
9/12/06 ^{3,5}	35-75	48.27	867.21	818.94	
9/14/06 ³	35-75	48.23	867.21	818.98	
11/28/06 ^{3,5}	35-75	48.03	867.21	819.18	
11/29/06 ³	35-75	48.10	867.21	819.11	

See Page 11 for Notes

**Table 1. Results of Depth to Groundwater Measurements, May 2000 - March 2006
Tyson Wash WQARF Site, Quartzsite, Arizona**

WELL ID (ADWR Registration Number)	Date Measured	Well Screened Interval (ft)	Depth To Groundwater (ft below Measuring Pt)	Measuring Point Elevation (ft above MSL)	Groundwater Table Elevation (ft above MSL)
QMW-8 (55-577298) 58692	2/27/07 ^{3,5}	35-75	47.66	867.21	819.55
	3/1/07 ³	35-75	47.71	867.21	819.50
	5/15/07 ^{3,5}	35-75	47.48	867.21	819.73
	5/17/07 ³	35-75	47.48	867.21	819.73
QMW-9 (55-577299) 58693	05/11/00	35-70	53.30	869.03	815.73
	06/11/00	35-70	52.26	869.03	816.77
	07/11/00	35-70	51.31	869.03	817.72
	08/11/00	35-70	50.90	869.03	818.13
	09/11/00	35-70	50.29	869.03	818.74
	10/11/00	35-70	49.89	869.03	819.14
	11/11/00	35-70	50.29	869.03	818.74
	12/11/00	35-70	50.84	869.03	818.19
	01/11/01	35-70	51.29	869.03	817.74
	02/11/01	35-70	51.82	869.03	817.21
	03/11/01	35-70	51.67	869.03	817.36
	04/11/01	35-70	51.92	869.03	817.11
	06/11/01	35-70	51.71	869.03	817.32
	07/11/01	35-70	51.19	869.03	817.84
	08/11/01	35-70	50.25	869.03	818.78
	09/11/01	35-70	49.80	869.03	819.23
	10/11/01	35-70	49.18	869.03	819.85
	11/11/01	35-70	48.77	869.03	820.26
	12/11/01	35-70	48.64	869.03	820.39
	01/11/02	35-70	47.78	869.03	821.25
	12/12/02 ¹	35-70	45.65	869.03	823.38
	02/12/03 ¹	35-70	45.60	869.03	823.43
	05/14/03 ¹	35-70	45.19	869.03	823.84
	09/04/03 ¹	35-70	45.01	869.03	824.02
	12/04/03 ¹	35-70	44.70	869.03	824.33
	03/03/04 ¹	35-70	44.11	869.03	824.92
	06/09/04 ³	35-70	43.68	869.03	825.35
	09/22/04 ³	35-70	43.53	869.03	825.50
	12/08/04 ³	35-70	43.21	869.03	825.82
	02/16/05 ³	35-70	42.53	869.03	826.50
	05/25/05 ³	35-70	41.63	869.03	827.40
10/03/05 ³	35-70	41.76	869.03	827.27	
12/7/05 ³	35-70	42.00	869.03	827.03	
3/1/06 ³	35-70	41.56	869.03	827.47	
5/23/06 ³	35-70	41.41	869.03	827.62	
9/14/06 ³	35-70	Inaccessible	869.03	NM	
11/28/06 ³	35-70	41.20	869.03	827.83	
3/1/07 ³	35-70	40.94	869.03	828.09	
5/17/07 ³	35-70	40.62	869.03	828.41	
QMW-10 (55-583806) 59643	04/11/01	45-75	54.99	869.77	814.78
	05/11/01	45-75	54.06	869.77	815.71
	06/11/01	45-75	54.10	869.77	815.67
	07/11/01	45-75	54.41	869.77	815.36
	08/11/01	45-75	54.58	869.77	815.19
	09/11/01	45-75	54.56	869.77	815.21
	10/11/01	45-75	54.42	869.77	815.35
	11/11/01	45-75	54.29	869.77	815.48
	12/11/01	45-75	53.73	869.77	816.04
	01/11/02	45-75	53.69	869.77	816.08
	02/11/02	45-75	53.82	869.77	815.95
	03/11/02	45-75	53.55	869.77	816.22
	04/04/02	45-75	53.43	869.77	816.34
	12/12/02 ¹	45-75	53.05	869.77	816.72
	02/12/03 ¹	45-75	53.00	869.77	816.77
	05/14/03 ¹	45-75	52.60	869.77	817.17
09/04/03 ¹	45-75	52.48	869.77	817.29	

See Page 11 for Notes

**Table 1. Results of Depth to Groundwater Measurements, May 2000 - March 2006
Tyson Wash WQARF Site, Quartzsite, Arizona**

WELL ID (ADWR Registration Number)	Date Measured	Well Screened Interval (ft)	Depth To Groundwater (ft below Measuring Pt)	Measuring Point Elevation (ft above MSL)	Groundwater Table Elevation (ft above MSL)
QMW-10 (55-583806) 59643	12/04/03 ¹	45-75	52.43	869.77	817.34
	03/03/04 ¹	45-75	52.14	869.77	817.63
	06/09/04 ³	45-75	52.18	869.77	817.59
	09/22/04 ³	45-75	51.90	869.77	817.87
	12/08/04 ³	45-75	51.74	869.77	818.03
	02/17/05 ³	45-75	51.39	869.77	818.38
	05/25/05 ³	45-75	51.10	869.77	818.67
	09/20/05 ³	45-75	50.61	869.77	819.16
	12/7/05 ³	45-75	50.30	869.77	819.47
	3/1/06 ³	45-75	49.79	869.77	819.98
	5/23/06 ³	45-75	49.62	869.77	820.15
	9/14/06 ³	45-75	49.44	869.77	820.33
	11/29/06 ³	45-75	49.37	869.77	820.40
	3/1/07 ³	45-75	48.94	869.77	820.83
5/17/07 ³	45-75	48.71	869.77	821.06	
QMW-11 (55-204757) 64687	09/22/04 ³	35-70	44.07	868.76	824.69
	12/08/04 ³	35-70	44.20	868.76	824.56
	02/16/05 ³	35-70	43.61	868.76	825.15
	09/20/05 ³	35-70	42.10	868.76	826.66
	12/7/05 ^{3,5}	35-70	41.75	868.76	827.01
	12/7/05 ³	35-70	41.74	868.76	827.02
	2/28/06 ^{3,5}	35-70	41.36	868.76	827.40
	3/1/06 ³	35-70	41.32	868.76	827.44
	5/22/06 ^{3,5}	35-70	41.34	868.76	827.42
	5/23/06 ³	35-70	41.31	868.76	827.45
	9/12/06 ^{3,5}	35-70	41.43	868.76	827.33
	9/14/06 ³	35-70	41.39	868.76	827.37
	11/28/06 ^{3,5}	35-70	41.25	868.76	827.51
	11/29/06 ³	35-70	41.32	868.76	827.44
	2/27/07 ^{3,5}	35-70	40.87	868.76	827.89
3/1/07 ³	35-70	40.95	868.76	827.81	
5/15/07 ^{3,5}	35-70	40.74	868.76	828.02	
5/17/07 ³	35-70	40.75	868.76	828.01	
QMW-12 (55-204757) 64688	09/22/04 ³	35-70	44.48	869.57	825.09
	12/08/04 ³	35-70	44.53	869.57	825.04
	02/16/05 ³	35-70	43.73	869.57	825.84
	05/25/05 ³	35-70	42.78	869.57	826.79
	09/20/05 ³	35-70	42.15	869.57	827.42
	12/7/05 ³	35-70	41.77	869.57	827.80
	3/1/06 ³	35-70	41.59	869.57	827.98
	5/23/06 ³	35-70	41.50	869.57	828.07
	9/14/06 ³	35-70	41.76	869.57	827.81
	11/29/06 ³	35-70	41.53	869.57	828.04
	3/1/07 ³	35-70	41.37	869.57	828.20
	5/17/07 ³	35-70	41.27	869.57	828.30
EW-1 (55-596439) 60797	03/26/03 ¹	35-70	45.38	869.08	823.70
	05/15/03 ^{1,2}	35-70	44.28	869.08	824.80
	06/12/03 ^{1,2}	35-70	44.15	869.08	824.93
	09/04/03 ^{1,2}	35-70	44.39	869.08	824.69
	12/03/03 ^{1,2}	35-70	44.53	869.08	824.55
	03/04/04 ^{1,2}	35-70	44.48	869.08	824.60
	06/08/04 ³	35-70	43.83	869.08	825.25
	09/23/04 ³	35-70	44.13	869.08	824.95
	12/07/04 ³	35-70	43.87	869.08	825.21
	02/18/05 ³	35-70	43.36	869.08	825.72
	05/25/05 ³	35-70	42.43	869.08	826.65
	09/20/05 ³	35-70	41.96	869.08	827.12
	12/6/05 ^{3,5}	35-70	42.81	869.08	826.27
	12/7/05 ³	35-70	41.92	869.08	827.16
	2/28/06 ^{3,5}	35-70	43.75	869.08	825.33
3/1/06 ³	35-70	41.41	869.08	827.67	

See Page 11 for Notes

**Table 1. Results of Depth to Groundwater Measurements, May 2000 - March 2006
Tyson Wash WQARF Site, Quartzsite, Arizona**

WELL ID (ADWR Registration Number)	Date Measured	Well Screened Interval (ft)	Depth To Groundwater (ft below Measuring Pt)	Measuring Point Elevation (ft above MSL)	Groundwater Table Elevation (ft above MSL)
	5/22/06 ^{3,5}	35-70	42.11	869.08	826.97
	5/23/06 ³	35-70	41.29	869.08	827.79
	9/12/06 ^{4,5}	35-70	41.37	869.08	827.71
	9/14/06 ³	35-70	40.81	869.08	828.27
	11/28/06 ^{3,5}	35-70	40.83	869.08	828.25
	11/29/06 ³	35-70	40.69	869.08	828.39
	2/27/07 ^{3,5}	35-70	40.10	869.08	828.98
	3/1/07 ³	35-70	40.07	869.08	829.01
	5/15/07 ^{3,5}	35-70	40.46	869.08	828.62
	5/17/07 ³	35-70	39.81	869.08	829.27
EW-2 (55-596441) 60798	03/26/03 ¹	35-70	44.63	868.25	823.62
	05/15/03 ^{1,2}	35-70	44.14	868.25	824.11
	06/12/03 ^{1,2}	35-70	44.13	868.25	824.12
	09/04/03 ^{1,2}	35-70	43.83	868.25	824.42
	12/03/03 ^{1,2}	35-70	43.84	868.25	824.41
	03/04/04 ^{1,2}	35-70	43.76	868.25	824.49
	06/08/04 ³	35-70	43.48	868.25	824.77
	09/23/04 ³	35-70	43.70	868.25	824.55
	12/07/04 ³	35-70	43.36	868.25	824.89
	02/18/05 ³	35-70	42.86	868.25	825.39
	05/25/05 ³	35-70	42.06	868.25	826.19
	09/20/05 ³	35-70	41.46	868.25	826.79
	12/6/05 ^{3,5}	35-70	43.27	868.25	824.98
	2/28/06 ^{3,5}	35-70	42.55	868.25	825.70
	3/1/06 ³	35-70	40.91	868.25	827.34
	5/22/06 ^{3,5}	35-70	42.84	868.25	825.41
	5/23/06 ³	35-70	40.82	868.25	827.43
	9/12/06 ^{3,5}	35-70	42.84	868.25	825.41
	9/14/06 ³	35-70	40.82	868.25	827.43
	11/28/06 ^{3,5}	35-70	41.38	868.25	826.87
11/29/06 ³	35-70	40.40	868.25	827.85	
2/27/07 ^{3,5}	35-70	41.13	868.25	827.12	
3/1/07 ³	35-70	39.83	868.25	828.42	
5/15/07 ^{3,5}	35-70	40.64	868.25	827.61	
5/17/07 ³	35-70	39.60	868.25	828.65	
EW-3 (55-205419) 62465	10/03/05 ³	35-70	40.64	866.08	825.44
	12/6/05 ^{3,5}	35-70	42.11	866.08	823.97
	12/7/05 ³	35-70	40.76	866.08	825.32
	3/1/06 ³	35-70	40.41	866.08	825.67
	5/22/06 ^{3,5}	35-70	42.70	866.08	823.38
	5/23/06 ³	35-70	40.51	866.08	825.57
	9/12/06 ^{3,5}	35-70	44.44	866.08	821.64
	9/14/06 ³	35-70	40.73	866.08	825.35
	11/28/06 ^{3,5}	35-70	44.07	866.08	822.01
	11/29/06 ³	35-70	40.54	866.08	825.54
	2/27/07 ^{3,5}	35-70	43.15	866.08	822.93
	3/1/07 ³	35-70	40.13	866.08	825.95
	5/15/07 ^{3,5}	35-70	43.23	866.08	822.85
5/17/07 ³	35-70	39.94	866.08	826.14	
EW-4 (55-205422) 62466	10/03/05 ³	35-70	40.84	866.29	825.45
	12/6/05 ^{3,5}	35-70	44.87	866.29	821.42
	12/7/05 ³	35-70	42.01	866.29	824.28
	2/28/06 ^{3,5}	35-70	43.18	866.29	823.11
	3/1/06 ³	35-70	41.35	866.29	824.94
	5/22/06 ^{3,5}	35-70	43.60	866.29	822.69
	5/23/06 ³	35-70	41.47	866.29	824.82
	9/12/06 ^{3,5}	35-70	43.60	866.29	822.69
	9/14/06 ³	35-70	41.47	866.29	824.82
	11/28/06 ^{3,5}	35-70	43.25	866.29	823.04
	11/29/06 ³	35-70	41.38	866.29	824.91
	2/27/07 ^{3,5}	35-70	42.60	866.29	823.69
	3/1/07 ³	35-70	40.94	866.29	825.35
5/15/07 ^{3,5}	35-70	42.71	866.29	823.58	
5/17/07 ³	35-70	40.76	866.29	825.53	

See Page 11 for Notes

**Table 1. Results of Depth to Groundwater Measurements, May 2000 - March 2006
Tyson Wash WQARF Site, Quartzsite, Arizona**

WELL ID (ADWR Registration Number)	Date Measured	Well Screened Interval (ft)	Depth To Groundwater (ft below Measuring Pt)	Measuring Point Elevation (ft above MSL)	Groundwater Table Elevation (ft above MSL)
EW-5 (55-205420) 65344	10/03/05 ³	35-70	45.62	865.67	820.05
	12/6/05 ^{3,5}	35-70	48.75	865.67	816.92
	12/7/05 ³	35-70	46.68	865.67	818.99
	2/28/06 ^{3,5}	35-70	47.00	865.67	818.67
	3/1/06 ³	35-70	46.51	865.67	819.16
	5/22/06 ^{3,5}	35-70	46.28	865.67	819.39
	5/23/06 ³	35-70	46.11	865.67	819.56
	9/12/06 ^{3,5}	35-70	48.21	865.67	817.46
	9/14/06 ³	35-70	46.69	865.67	818.98
	11/28/06 ^{3,5}	35-70	47.38	865.67	818.29
	11/29/06 ³	35-70	46.28	865.67	819.39
	2/27/07 ^{3,5}	35-70	46.96	865.67	818.71
	3/1/07 ³	35-70	45.91	865.67	819.76
	5/15/07 ^{3,5}	35-70	46.91	865.67	818.76
5/17/07 ³	35-70	46.80	865.67	818.87	
INJ-1 (55-596441) 60800	03/26/03 ¹	45-70	45.10	868.99	823.89
	05/15/03 ^{1,2}	45-70	43.92	868.99	825.07
	06/12/03 ^{1,2}	45-70	43.51	868.99	825.48
	09/04/03 ^{1,2}	45-70	44.40	868.99	824.59
	12/03/03 ^{1,2}	45-70	44.60	868.99	824.39
	03/04/04 ^{1,2}	45-70	44.57	868.99	824.42
	06/08/04 ³	45-70	43.72	868.99	825.27
	09/23/04 ³	45-70	43.70	868.99	825.29
	12/07/04 ³	45-70	43.92	868.99	825.07
	02/18/05 ³	45-70	43.43	868.99	825.56
	05/25/05 ³	45-70	42.45	868.99	826.54
	09/20/05 ³	45-70	41.97	868.99	827.02
	12/6/05 ^{3,5}	45-70	29.50	868.99	839.49
	12/7/05 ³	45-70	41.97	868.99	827.02
	2/28/06 ^{3,5}	45-70	37.18	868.99	831.81
	3/1/06/05 ³	45-70	41.45	868.99	827.54
	5/23/06 ³	45-70	41.31	868.99	827.68
	9/12/06 ^{3,5}	45-70	30.30	868.99	838.69
	9/14/06 ³	45-70	40.81	868.99	828.18
	11/28/06 ^{3,5}	45-70	28.50	868.99	840.49
11/29/06 ³	45-70	40.88	868.99	828.11	
2/27/07 ^{3,5}	45-70	34.20	868.99	834.79	
3/1/07 ³	45-70	40.11	868.99	828.88	
5/15/07 ^{3,5}	45-70	26.75	868.99	842.24	
5/17/07 ³	45-70	39.85	868.99	829.14	
INJ-2 (55-205421) 65345	10/03/05 ³	35-70	39.87	867.52	827.65
	12/6/05 ^{3,5}	35-70	0.00	867.52	867.52
	12/7/05 ³	35-70	37.73	867.52	829.79
	2/28/06 ^{3,5}	35-70	17.20	867.52	850.32
	3/1/06 ³	35-70	37.31	867.52	830.21
	5/22/06 ^{3,5}	35-70	0.00	867.52	867.52
	5/23/06 ³	35-70	37.26	867.52	830.26
	9/12/06 ^{3,5}	35-70	0.00	867.52	867.52
	9/14/06 ³	35-70	36.71	867.52	830.81
	11/28/06 ^{3,5}	35-70	0.00	867.52	867.52
	11/29/06 ³	35-70	36.80	867.52	830.72
	2/27/07 ^{3,5}	35-70	0.00	867.52	867.52
	3/1/07 ³	35-70	37.26	867.52	830.26
	5/15/07 ^{3,5}	35-70	0.00	867.52	867.52
5/17/07 ³	35-70	37.00	867.52	830.52	
Adams North	09/22/04 ³		42.32		
	12/08/04 ³		42.17		
	02/18/05 ³		41.18		
	05/24/05 ³		40.32		
	09/20/05 ³		39.81		
	12/7/05 ³		39.51		
	5/22/06 ³		39.48		

See Page 11 for Notes

**Table 1. Results of Depth to Groundwater Measurements, May 2000 - March 2006
Tyson Wash WQARF Site, Quartzsite, Arizona**

WELL ID (ADWR Registration Number)	Date Measured	Well Screened Interval (ft)	Depth To Groundwater (ft below Measuring Pt)	Measuring Point Elevation (ft above MSL)	Groundwater Table Elevation (ft above MSL)
Adams North	9/14/06 ³		40.03		
	11/29/06 ³		39.67		
	3/1/07 ²		39.41		
	5/17/07 ³		39.67		
Rhoades East	09/22/04 ³		43.42		
	12/08/04 ³		43.36		
	02/18/05 ²		42.87		
	05/25/05 ²		42.05		
	9/20/05 ²		41.50		
	12/7/05 ³		41.41		
	3/1/06 ²		41.14		
	5/22/06 ³		41.29		
	9/14/06 ³		41.68		
	11/29/06 ³		41.41		
	3/1/07 ³		41.10		
	5/15/07 ³		41.07		

Notes:

- Measuring points are located at the top north edge of the sanitary well seal at each well.
- Groundwater data collected by dedicated data loggers at approximately 12:00pm on the given date.
- Well QMW-6 has been inaccessible since March 2002 due to road construction activities.
- Groundwater data was not collected due to malfunctioning pressure transducers from wells QMW-2 QMW-5, and QMW-10 between 5/02 and 11/02; and from well QMW-9 between 2/02 and 11/02.
- ¹ - Groundwater data collected manually using a Heron H.01L Interface Probe.
- ² - Groundwater elevation not fully equilibrated following remedial system shut-down
- ³ - Groundwater data collected manually using a Solinst Water Level Probe
- ⁴ - Depth to water in QMW-7 was read incorrectly on 12/07/04. Therefore, the groundwater elevation is omitted from the table.
- ⁵ - Depth to water measured while remediation system operational.

MSL - Mean Sea Level

Checked by: JNC

Table 2. Results of Groundwater Sample Analyses - Monitoring and Remediation Wells
Tyson Wash WQARF Site, Quartzsite, Arizona

Well ID (ADWR No.)	Date Sampled	Pump Intake Depth (ft)	Sample Flow Rate (gpm)	Volatile Organic Compound Concentrations (µg/l)			
				PCE	TCE	cis-1,2-DCE	1,1-DCE
QMW-1 (55-561847)	07/30/97	68	--	97	4	--	--
	10/29/97	68	--	81	3.1	--	--
	05/13/98	68	--	73	2.6	--	--
	08/12/98	68	--	76	<2.5	--	--
	11/16/98	68	--	56	1.8	--	--
	02/22/99	68	--	34	1.3	--	--
	05/27/99	68	--	51	2.3	--	--
	05/11/00	68	6.6	49	<2	<2	<5
	05/11/00 D	68	6.6	66	2.4	<2	<5
	08/09/00	68	6.6	62	2.8	<2	<5
	10/30/00	68	--	41	2.7	<1	<2
	02/12/01	68	6.2	50	2.5	<1	<2
	05/08/01	68	6.2	54	2.7	<1	<2
	08/14/01	68	--	NA	NA	NA	NA
	11/20/01	68	6.5	34	2.7	<1	<2
	03/27/02	68	4.5	51	2.5	<1	<2
	02/18/03	68	0.052	38	2.4	<2	<5
	05/15/03	60	0.031	22	2.3	<2	<5
	09/04/03	60	0.078	28	4.3	<2	<5
	12/03/03	60	0.039	38	5.0	<2	<5
	03/04/04	60	0.045	44	3.6	<2	<5
	06/08/04	60	0.044	38	4.9	<1	<2
	09/23/04	60	0.046	34	3.1	<1	<2
	12/07/04	60	0.045	69.6	4.4	<1	<1
	02/17/05	60	0.050	83	4.1	<1	<1
	05/25/05	60	0.050	80	4.6	<1	<2
	09/21/05	60	0.040	98	5.6	<1	<2
	12/07/05	60	0.044	63	3.0	<1	<2
	03/01/06	60	0.045	39	1.8	<1	<2
	05/27/06	60	0.046	30	1.5	<1	<2
09/13/06	60	0.046	22	1.1	<1	<2	
11/29/06	60	0.046	19	1.1	<1	<2	
02/28/07	60	0.046	14	<1	<1	<2	
05/17/07	60	0.046	16	<1	<1	<2	
QMW-2 (55-561849)	07/30/97	68	--	<2	<2	--	--
	10/29/97	68	--	<0.5	<0.5	--	--
	11/16/97	68	--	<0.5	<0.5	--	--
	05/13/98	68	--	<0.5	<0.5	--	--
	08/12/98	68	--	<0.5	<0.5	--	--
	11/16/98	68	--	<0.5	<0.5	--	--
	02/22/99	68	--	<0.5	<0.5	--	--
	05/27/99	68	--	<2	<2	--	--
	11/04/99	68	--	<2	<2	<2	<2
	05/11/00	68	6.4	<2	<2	<2	<5
	08/09/00	68	6.5	<2	<2	<2	<5
	10/30/00	68	--	<1	<1	<1	<2
	02/12/01	68	5.1	<1	<1	<1	<2
	05/08/01	68	6.3	<1	<1	<1	<2
	08/14/01	68	6.3	<1	<1	<1	<2
	11/20/01	68	6.0	<1	<1	<1	<2
	03/27/02	68	3.5	<1	<1	<1	<2
	02/12/03	68	0.036	9.1	<2	<2	<5
	05/14/03	60	0.031	3.5	<2	<2	<5
	09/04/03	60	0.065	<2	<2	<2	<5
	12/04/03	60	0.039	6.0	<2	<2	<5
	03/03/04	60	0.042	2.2	2.3	<2	<5
	06/09/04	60	0.053	8.0	1.0	<1	<2
	09/22/04	60	0.044	<1	<1	<1	<2
	12/08/04	60	0.044	8.2	<1	<1	<1
	02/17/05	60	0.05	1.5	<1	<1	<1
	05/25/05	60	0.05	2.2	<1	<1	<2
	10/03/05	60	0.05	<1	<1	<1	<2
	12/08/05	60	0.05	1.2	<1	<1	<2
	03/01/06	60	0.052	<1	<1	<1	<2
05/23/06	60	0.046	<1	<1	<1	<2	
09/14/06			Well was inaccessible and was not sampled				
11/28/06	60	0.046	<1	<1	<1	<2	
02/27/07	60	0.046	<1	<1	<1	<2	
05/17/07	60	0.046	<1	<1	<1	<2	
QMW-3 (55-561848)	07/30/97	68	--	160	10	--	--
	07/30/97 D	68	--	150	9.9	--	--
	10/29/97	68	--	160	9.1	--	--
	10/29/97 D	68	--	150	8.2	--	--
	12/08/97	68	--	67	<5	--	--
	05/13/98	68	--	110	4.8	--	--
05/13/98 D	68	--	110	4.9	--	--	
ADEQ AWQS				5	5	70	7

See Page 7 for Notes

Table 2. Results of Groundwater Sample Analyses - Monitoring and Remediation Wells
Tyson Wash WQARF Site, Quartzsite, Arizona

Well ID (ADWR No.)	Date Sampled	Pump Intake Depth (ft)	Sample Flow Rate (gpm)	Volatile Organic Compound Concentrations (µg/l)			
				PCE	TCE	cis-1,2-DCE	1,1-DCE
QMW-3 (55-561848)	08/12/98	68	--	120	<2.5	--	--
	11/16/98	68	--	67	<0.5	--	--
	02/22/99	68	--	66	3	--	--
	05/27/99	68	--	73	3.7	--	--
	05/27/99 D	68	--	73	3.4	--	--
	05/11/00	68	7.2	130	4.1	<2	<5
	09/08/00	68	6.8	80	4.3	1.4	<2
	09/08/00	68	6.8	81	4.7	1.6	<2
	10/30/00	68	--	96	4.7	1.5	<2
	10/30/00 D	68	--	98	5.1	1.5	<2
	02/12/01	68	5.8	130	4.5	1.2	<2
	05/08/01	68	6.0	130	4.7	1.3	<2
	08/15/01	68	7.1	110	5.7	1.7	<2
	11/20/01	68	7.1	160	5.2	1.5	<2
	03/27/02	68	4.5	140	5.2	1.6	<2
	02/18/03	68	0.047	69	4.5	<2	<5
	02/18/03 D	60	0.047	75	4.6	<2	<5
	05/15/03	60	--	40	3.3	<2	<5
	09/04/03	60	0.1	46	3.7	<2	<5
	12/03/03	60	0.039	70	5.3	<2	<5
	03/04/04	60	0.049	83	5.1	<2	<5
	3/04/04 D	60	0.049	92	5.4	<2	<5
	06/08/04	60	0.044	60	4.0	1.1	<2
	6/08/04 D	60	0.044	68	5.5	1.4	<2
	09/23/04	60	0.053	52	3.8	<1	<2
	9/23/04 D	60	0.053	53	4.0	<1	<2
	12/07/04	60	0.044	84.2	4.5	1.0	<1
	12/07/04 D	60	0.044	95.4	4.6	<1	<1
	02/17/05	60	0.046	100	4.4	1.1	<1
	02/17/05 D	60	0.046	100	4.3	1.1	<1
	05/25/05	60	0.046	61	4.5	<1	<2
	05/25/05 D	60	0.046	130	4.8	1.2	<2
	09/21/05	60	0.045	160	6.0	1.1	<2
	9/21/05 D	60	0.045	150	5.6	1.1	<2
12/07/05	60	0.049	200	6.2	1.3	<2	
12/7/05 D	60	0.049	200	6.5	1.3	<2	
03/01/06	60	0.044	190	6.2	1.2	<2	
3/01/06 D	60	0.044	200	6.5	1.2	<2	
05/23/06	60	0.046	140	5.2	<1	<2	
5/23/06 D	60	0.046	140	5.1	<1	<2	
09/13/06	60	0.046	140	4.7	<1	<2	
9/13/06 D	60	0.046	140	5.0	<1	<2	
11/29/06	60	0.046	130	4.4	<1	<2	
11/29/06 D	60	0.046	110	4.1	<1	<2	
02/28/07	60	0.046	130	4.0	<1	<2	
2/28/07 D	60	0.046	100	4.0	<1	<2	
05/17/07	60	0.046	93	3.2	<1	<2	
5/17/07 D	60	0.046	91	3.2	<1	<2	
QMW-4 (55-567650)	03/26/98	62	--	29	<1	--	--
	05/13/98	62	--	33	1	--	--
	08/12/98	62	--	32	0.59	--	--
	11/16/98	62	--	39	0.97	--	--
	02/22/99	62	--	45	1.4	--	--
	02/22/99 D	62	--	38	1.2	--	--
	05/27/99	62	--	57	<2	--	--
	05/11/00	62	6.4	57	<2	<2	<5
	09/08/00	62	--	33	1.6	<1	<2
	10/30/00	62	--	40	1.7	<1	<2
	02/12/01	62	5.5	38	1.2	<1	<2
	05/08/01	62	6.0	43	1.4	<1	<2
	05/08/01 D	62	6.0	42	1.3	<1	<2
	08/14/01	62	5.8	44	1.6	<1	<2
	11/20/01	62	7.0	36	1.4	<1	<2
	03/27/02	62	3.0	52	3.1	<1	<2
	02/12/03	62	0.052	36	2.9	<2	<5
	05/15/03	60	0.031	14	<2	<2	<5
	09/04/03	60	0.065	26	3.1	<2	<5
	09/04/03 D	60	0.065	25	3.1	<2	<5
	12/03/03	60	0.039	26	5.0	<2	<5
	03/03/04	60	0.038	31	3.6	<2	<5
	06/08/04	60	0.044	19	4.1	<1	<2
	09/23/04	60	0.053	18	2.6	<1	<2
12/08/04	60	0.045	55.9	3.7	<1	<1	
02/18/05	60	0.046	49	2.9	<1	<1	
05/25/05	60	0.043	18	2.0	<1	<2	
09/21/05	60	0.044	80	4.5	<1	<2	
12/07/05	60	0.045	96	4.9	<1	<2	
ADEQ AWQS				5	5	70	7

See Page 7 for Notes

Table 2. Results of Groundwater Sample Analyses - Monitoring and Remediation Wells
Tyson Wash WQARF Site, Quartzsite, Arizona

Well ID (ADWR No.)	Date Sampled	Pump Intake Depth (ft)	Sample Flow Rate (gpm)	Volatile Organic Compound Concentrations (µg/l)			
				PCE	TCE	cis-1,2-DCE	1,1-DCE
QMW-4 (55-567650)	03/01/06	60	0.049	97	5.0	<1	<2
	05/23/06	60	0.046	76	4.0	<1	<2
	09/12/06	60	0.046	62	3.2	<1	<2
	11/29/06	60	0.046	76	3.7	<1	<2
	02/28/07	60	0.046	89	3.9	<1	<2
	05/17/07	60	0.046	79	3.4	<1	<2
QMW-5 (55-567649)	04/03/98	55	--	130	<5	--	--
	05/13/98	55	--	130	<5	--	--
	08/12/98	55	--	160	<5	--	--
	08/12/98 D	55	--	180	<2.5	--	--
	11/16/98	55	--	86	<10	--	--
	11/16/98 D	55	--	69	<10	--	--
	02/22/99	55	--	37	1.1	--	--
	05/27/99	55	--	38	<2	--	--
	05/11/00	55	6.6	60	<2	<2	<5
	09/08/00	55	--	34	1.3	<1	<2
	10/30/00	55	--	34	1.4	<1	<2
	02/12/01	55	4.9	40	1.1	<1	<2
	05/08/01	55	6.1	46	1.1	<1	<2
	08/14/01	55	7.0	46	1.3	<1	<2
	11/20/01	55	6.0	38	1.2	<1	<2
	11/20/01 D	55	6.0	37	1.2	<1	<2
	03/27/02	55	3.0	30	1.1	<1	<2
	03/27/02 D	55	3.0	31	1.1	<1	<2
	02/18/03	55	0.057	8.7	<2	<2	<5
	05/14/03	55	0.031	3.1	<2	<2	<5
	09/04/03	55	--	6.6	2.7	<2	<5
	12/03/03	55	0.039	31	3.2	<2	<5
	03/04/04	55	0.039	11	<2	<2	<5
	06/08/04	55	0.050	12	2.6	<1	<2
	09/23/04	50	0.046	4.7	1.5	<1	<2
	12/07/04	50	0.045	10.5	1.8	<1	<1
	02/17/05	50	0.044	13	1.7	<1	<1
	05/25/05	50	0.050	6.0	<1	<1	<2
	09/21/05	50	0.049	20.0	1.9	<1	<2
	12/08/05	50	0.050	17	2.0	<1	<2
03/01/06	50	0.045	16	1.6	<1	<2	
05/23/06	50	0.046	12	1.5	<1	<2	
09/13/06	50	0.046	8.0	1.3	<1	<2	
11/29/06	50	0.046	7.5	1.3	<1	<2	
02/28/07	50	0.046	7.2	1.1	<1	<2	
05/17/07	50	0.046	6.1	1.2	<1	<2	
QMW-6 ¹ (55-578364)	05/11/00	68	6.4	<2	<2	<1	<5
	09/08/00	68	--	<1	<1	<1	<2
	10/30/00	68	--	<1	<1	<1	<2
	02/12/01	68	8.5	<1	<1	<1	<2
	05/08/01	68	9.5	<1	<1	<1	<2
	08/14/01	68	--	<1	<1	<1	<2
	11/20/01	68	8.2	<1	<1	<1	<2
	03/27/02	68	3.5	<1	<1	<1	<2
QMW-7 (55-577300)	05/11/00	68	7.0	7	<2	<2	<5
	08/09/00	68	9.4	11	<2	<2	<5
	10/30/00	68	--	12	<1	<1	<2
	02/12/01	68	8.9	9	<1	<1	<2
	05/08/01	68	9.8	10	<1	<1	<2
	08/14/01	68	7.3	11	<1	<1	<2
	11/20/01	68	10.1	10	<1.0	<1	<2
	03/27/02	68	5.0	11	<1	<1	<2
	02/18/03	68	0.029	6.7	<2	<2	<5
	05/14/03	60	0.033	3.0	<2	<2	<5
	09/04/03	60	0.068	6.3	<2	<2	<5
	12/03/03	60	0.039	21	<2	<2	<5
	12/03/03 D	60	0.039	20	<2	<2	<5
	03/04/04	60	0.050	13	<2	<2	<5
	06/08/04	60	0.046	9.7	1.2	<1	<2
	09/23/04	60	0.053	1.9	<1	<1	<2
	12/07/04	60	0.044	6.7	<1	<1	<1
	02/17/05	60	0.046	3.9	<1	<1	<1
	05/26/05	60	0.046	10.0	<1	<1	<2
	09/21/05	60	0.045	4.2	<1	<1	<2
12/08/05	60	0.045	4.5	<1	<1	<2	
03/01/06	60	0.049	3.9	<1	<1	<2	
05/23/06	60	0.046	2.4	<1	<1	<2	
09/13/06	60	0.046	3.0	<1	<1	<2	
11/29/06	60	0.046	3.4	<1	<1	<2	
ADEQ AWQS				5	5	70	7

See Page 7 for Notes

Table 2. Results of Groundwater Sample Analyses - Monitoring and Remediation Wells
Tyson Wash WQARF Site, Quartzsite, Arizona

Well ID (ADWR No.)	Date Sampled	Pump Intake Depth (ft)	Sample Flow Rate (gpm)	Volatile Organic Compound Concentrations (µg/l)			
				PCE	TCE	cis-1,2-DCE	1,1-DCE
QMW-7 (55-577300)	02/28/07	60	0.046	2.3	<1	<1	<2
	05/16/07	60	0.046	2.4	<1	<1	<2
QMW-8 (55-577298)	05/11/00	68	5.0	2	<2	<2	<5
	08/09/00	68	6.2	4	<2	<2	<5
	10/30/00	68	--	4	<1	<1	<2
	02/12/01	68	4.9	5	<1	<1	<2
	02/12/01 D	68	4.9	4	<1	<1	<2
	05/08/01	68	5.8	4	<1	<1	<2
	08/14/01	68	4.2	5.1	<1	<1	<2
	11/20/01	68	5.8	3	<1	<1	<2
	03/27/02	68	4.0	4.6	<1	<1	<2
	02/12/03	68	0.031	5.8	<2	<2	<5
	05/15/03	60	0.031	3.8	<2	<2	<5
	09/04/03	60	0.068	9.7	<2	<2	<5
	12/03/03	60	0.039	14	2.4	<2	<5
	03/03/04	60	0.044	5.2	<2	<2	<5
	06/08/04	60	0.038	9.6	2.0	<1	<2
	09/23/04	60	0.044	6.9	<1	<1	<2
	12/08/04	60	0.045	18.8	<1	<1	<1
	02/18/05	60	0.046	15	<1	<1	<1
	05/25/05	60	0.043	<1	<1	<1	<2
	09/21/05	60	0.050	15	<1	<1	<2
	12/07/05	60	0.045	11	<1	<1	<2
03/01/06	60	0.044	14	<1	<1	<2	
05/23/06	60	0.046	11	<1	<1	<2	
09/12/06	60	0.046	8.7	<1	<1	<2	
11/29/06	60	0.046	11	<1	<1	<2	
02/28/07	60	0.046	11	<1	<1	<2	
05/17/07	60	0.046	10	<1	<1	<2	
QMW-9 (55-577299)	05/11/00	68	6.8	<2	<2	<1	<5
	09/08/00	68	--	<1	<1	<1	<2
	10/30/00	68	--	<1	<1	<1	<2
	02/12/01	68	5.3	<1	<1	<1	<2
	05/08/01	68	6.0	<1	<1	<1	<2
	08/14/01	68	6.8	1.5	<1	<1	<2
	11/20/01	68	6.3	<1	<1	<1	<2
	03/27/02	68	3.5	<1	<1	<1	<2
	02/12/03	68	0.031	4.0	<2	<2	<5
	05/14/03	60	0.03	3.2	<2	<2	<5
	09/04/03	60	0.062	<2	2.5	<2	<5
	12/04/03	60	0.039	7.4	<2	<2	<5
	03/03/04	60	0.034	<2	<2	<2	<5
	06/09/04	60	0.045	9.0	1.4	<1	<2
	09/22/04	60	0.046	<1	<1	<1	<2
	12/08/04	60	0.045	6.5	<1	<1	<1
	02/17/05	60	0.045	1.3	<1	<1	<1
	05/25/05	60	0.043	4.8	<1	<1	<2
	10/03/05	60	0.049	<1	<1	<1	<2
	12/08/05	60	0.045	1.5	<1	<1	<2
	03/01/06	60	0.049	1.8	<1	<1	<2
05/23/06	60	0.046	<1	<1	<1	<2	
09/13/06				Well was inaccessible and was not sampled			
11/28/06	60	0.046	<1	<1	<1	<2	
02/27/07	60	0.046	<1	<1	<1	<2	
05/17/07	60	0.046	<1	<1	<1	<2	
QMW-10 (55-583806)	03/06/01	68	5.8	<1	<1	<1	<2
	05/08/01	68	5.7	<1	<1	<1	<2
	08/14/01	68	6.5	<1	<1	<1	<2
	11/20/01	68	6.3	2	<1	<1	<2
	03/27/02	68	5.0	<1	<1	<1	<2
	02/12/03	68	0.047	<2	<2	<2	<5
	05/14/03	60	0.031	3.7	<2	<2	<5
	09/04/03	60	0.039	<2	4	<2	<5
	12/04/03	60	0.039	10	<2	<2	<5
	03/03/04	60	0.045	2.1	<2	<2	<2
	06/09/04	60	0.050	12	1.5	<1	<2
	09/23/04	60	0.044	10	<1	<1	<2
	12/08/04	60	0.045	7.7	<1	<1	<1
	02/17/05	60	0.044	5.1	<1	<1	<1
	05/26/05	60	0.046	6.6	<1	<1	<2
	09/21/05	60	0.049	13.0	<1	<1	<2
	12/08/05	60	0.044	11	<1	<1	<2
	03/01/06	60	0.045	14	<1	<1	<2
05/23/06	60	0.046	9.2	<1	<1	<2	
09/12/06	60	0.046	8.4	<1	<1	<2	
11/29/06	60	0.046	9.2	<1	<1	<2	
ADEQ AWQS				5	5	70	7

See Page 7 for Notes

Table 2. Results of Groundwater Sample Analyses - Monitoring and Remediation Wells
Tyson Wash WQARF Site, Quartzsite, Arizona

Well ID (ADWR No.)	Date Sampled	Pump Intake Depth (ft)	Sample Flow Rate (gpm)	Volatile Organic Compound Concentrations (µg/l)			
				PCE	TCE	cis-1,2-DCE	1,1-DCE
QMW-10 (55-583806)	02/27/07	60	0.046	9.9	<1	<1	<2
	05/17/07	60	0.046	8.8	<1	<1	<2
QMW-11	09/22/04	60	0.046	2.5	<1	<1	<2
	12/08/04	60	0.044	15.4	<1	<1	<1
	02/17/05	60	0.046	7.4	<1	<1	<1
	05/26/05	60	0.043	11.0	<1	<1	<2
	09/21/05	60	0.044	12.0	<1	<1	<2
	12/08/05	60	0.045	18	<1	<1	<2
	03/01/06	60	0.045	12	<1	<1	<2
	05/23/06	60	0.046	10	<1	<1	<2
	09/12/06	60	0.046	8.4	<1	<1	<2
	11/29/06	60	0.046	9.5	<1	<1	<2
	02/27/07	60	0.046	9.3	<1	<1	<2
	05/17/07	60	0.046	11	<1	<1	<2
	QMW-12	09/22/04	60	0.046	1.6	<1	<1
12/07/04		60	0.045	28.1	<1	<1	<1
02/17/05		60	0.044	2.4	<1	<1	<1
05/26/05		60	0.050	3.1	<1	<1	<2
09/21/05		60	0.045	2.3	<1	<1	<2
12/08/05		60	0.044	3.8	<1	<1	<2
03/01/06		60	0.045	2.0	<1	<1	<2
05/23/06		60	0.046	1.9	<1	<1	<2
09/12/06		60	0.046	2.2	<1	<1	<2
11/29/06		60	0.046	1.8	<1	<1	<2
02/27/07		60	0.046	1.6	<1	<1	<2
05/16/07		60	0.046	1.5	<1	<1	<2
OB-2		08/09/00	68	--	5.7	<2	<2
INFLUENT	04/07/03	--	--	89	4	0.74	4
EFFLUENT 1	04/07/03	--	--	--	--	<0.5	<0.5
EFFLUENT 2	04/07/03	--	--	--	--	<0.5	<0.5
EFF	06/08/04	--	--	1.1	<1	<1	<2
	02/18/05	--	--	8.4	<1	<1	<2
	05/25/05	--	--	<1	<1	<1	<2
	10/20/05	--	--	<1	<1	<1	<2
	12/06/05	--	--	1.5	<1	<1	<2
	03/02/06	--	--	6.4	<1	<1	<2
	05/24/06	--	--	<1	<1	<1	<2
	09/12/06	--	--	<1	<1	<1	<2
	11/28/06	--	--	<1	<1	<1	<2
	02/27/07	--	--	<1	<1	<1	<2
	05/15/07	--	--	<1	<1	<1	<2
INT	05/24/06	--	--	<1	<1	<1	<2
	09/12/06	--	--	2.5	<1	<1	<2
	11/28/06	--	--	<1	<1	<1	<2
	02/27/07	--	--	<1	<1	<1	<2
	05/15/07	--	--	<1	<1	<1	<2
EW-1 (55-596439)	03/26/03	55.5	0.033	28	2.2	<2	<5
	05/15/03	60	--	24	<2	<2	<5
	06/12/03	60	--	15	<2	<2	<5
	07/16/03	60	2.74	12	<2	<2	<5
	09/04/03	60	2.89	9.7	<2	<2	<5
	10/14/03	60	--	6.4	<2	<2	<5
	11/13/03	60	2.5	4.7	<2	<2	<5
	12/03/03	60	2.92	3.8	<2	<2	<5
	02/10/04	60	--	3.3	<2	<2	<5
	03/04/04	60	--	2.5	<2	<2	<5
	06/08/04	60	--	2.7	<1	<1	<2
	09/23/04	60	--	2.3	<1	<1	<2
	12/07/04	60	--	4.1	<1	<1	<1
	02/18/05	60	--	7.8	<1	<1	<1
	05/25/05	60	--	1.5	<1	<1	<2
	09/21/05	60	--	<1	<1	<1	<2
	12/06/05	60	1.00	<1	<1	<1	<2
	03/02/06	60	1.00	2.1	<1	<1	<2
	05/24/06	60	1.00	4.2	<1	<1	<2
09/12/06	60	1.00	1.8	<1	<1	<2	
11/28/06	60	1.00	2.9	<1	<1	<2	
02/27/07	60	1.00	1.2	<1	<1	<2	
05/15/07	60	1.00	4.5	<1	<1	<2	
EW-2 (55-596440)	03/26/03	55.5	0.068	30	2.1	<2	<5
	05/15/03	60	--	56	2.2	<2	<5
	06/12/03	60	--	34	<2	<2	<5
	07/16/03	60	3.05	35	<2	<2	<5
	09/04/03	60	2.96	15	<2	<2	<5
	10/14/03	60	--	4.4	<2	<2	<5
	11/13/03	60	2.7	4.1	<2	<2	<5
	12/04/03	60	2.94	2.4	<2	<2	<5
ADEQ AWQS				5	5	70	7

See Page 7 for Notes

Table 2. Results of Groundwater Sample Analyses - Monitoring and Remediation Wells
Tyson Wash WQARF Site, Quartzsite, Arizona

Well ID (ADWR No.)	Date Sampled	Pump Intake Depth (ft)	Sample Flow Rate (gpm)	Volatile Organic Compound Concentrations (µg/l)			
				PCE	TCE	cis-1,2-DCE	1,1-DCE
EW-2 (55-596440)	02/10/04	60		2.5	<2	<2	<5
	03/04/04	60		2.7	<2	<2	<5
	06/08/04	60		18	<1	<1	<2
	09/23/04	60		6.1	<1	<1	<2
	12/07/04	60		26.6	1.2	<1	<1
	02/18/05	60		13.0	<1	<1	<1
	05/25/05	60		22.0	<1	<1	<2
	09/21/05	60		9.2	<1	<1	<2
	12/06/05	60	2.00	16	<1	<1	<2
	03/02/06	60	2.00	23	<1	<1	<2
	05/24/06	60	2.00	2.6	<1	<1	<2
	09/12/06	60	2.00	<1.0	<1	<1	<2
	11/28/06	60	2.00	<1.0	<1	<1	<2
	02/27/07	60	2.00	<1.0	<1	<1	<2
	05/15/07	60	2.00	<1.0	<1	<1	<2
EW-3 (55-205419)	10/03/05	60	0.05	27.0	1.2	<1	<2
	12/06/05	60	2.00	120	4.4	1.1	<2
	12/06/05D	60	2.00	120	4.3	<1	<2
	03/02/06	60	2.00	120	3.9	<1	<2
	3/02/06D	60	2.00	120	4.0	<1	<2
	05/24/06	60	2.00	95	3.3	<1	<2
	5/24/06D	60	2.00	97	3.4	<1	<2
	09/12/06	60	2.00	89	3.1	<1	<2
	9/12/06D	60	2.00	89	2.9	<1	<2
	11/28/06	60	2.00	110	3.0	<1	<2
	11/28/06D	60	2.00	100	3.0	<1	<2
	02/27/07	60	2.00	78	2.5	<1	<2
	2/27/07D	60	2.00	90	2.6	<1	<2
	05/15/07	60	2.00	82	2.6	<1	<2
05/15/07D	60	2.00	88	2.7	<1	<2	
EW-4 (55-205422)	10/03/05	60	0.045	6.6	<1	<1	<2
	12/06/05	60	2.00	55	3.4	<1	<2
	03/02/06	60	2.00	54	3.2	<1	<2
	05/24/06	60	2.00	39	2.5	<1	<2
	09/12/06	60	2.00	40	2.4	<1	<2
	11/28/06	60	2.00	55	2.7	<1	<2
	02/27/07	60	2.00	43	2.4	<1	<2
05/15/07	60	2.00	52	2.6	<1	<2	
EW-5 (55-20520)	10/03/05	60	0.045	<1	<1	<1	<2
	12/06/05	60	1.00	2.0	<1	<1	<2
	03/02/06	60	1.00	5.3	<1	<1	<2
	05/24/06	60	1.00	30	1.3	<1	<2
	09/12/06	60	1.00	<1	<1	<1	<2
	11/28/06	60	1.00	<1	<1	<1	<2
	02/27/07	60	1.00	1.0	<1	<1	<2
05/15/07	60	1.00	1.6	<1	<1	<2	
INJ-1 (55-596441)	03/26/03	55.5	0.068	52	3.5	<2	<5
	05/15/03	60	--	7.5	<2	<2	<5
	06/12/03	60	0.031	3.2	<2	<2	<5
	07/16/03	60	0.039	3.4	<2	<2	<5
	09/04/03	60	0.034	4.5	<2	<2	<5
	10/14/03	60	0.039	<2	3.2	<2	<5
	11/13/03	60	0.039	<2	3.5	<2	<5
	12/03/03	60	0.039	<2	3.3	<2	<5
	02/10/04	60		<2	2.6	<2	<5
	03/04/04	60	0.049	28	<2	<2	<5
	06/08/04	60	0.046	7.1	1.8	<1	<2
	09/23/04	60	0.046	<1	<1	<1	<2
	12/07/04	60		6.1	<1	<1	<1
	02/18/05	60	0.05	15	<1	<1	<1
	05/25/05	60	0.05	<1	<1	<1	<2
	09/21/05	60	0.045	3	<1	<1	<2
	12/06/05	60	0.045	2.0	<1	<1	<2
	03/02/06	60	0.044	5.9	<1	<1	<2
	05/23/06	60	0.044	<1	<1	<1	<2
	09/12/06	60	0.046	1.4	<1	<1	<2
11/29/06	60	0.046	<1	<1	<1	<2	
02/28/07	60	0.046	<1	<1	<1	<2	
05/17/07	60	0.046	<1	<1	<1	<2	
ADEQ AWQS				5	5	70	7

See Page 7 for Notes

**Table 2. Results of Groundwater Sample Analyses - Monitoring and Remediation Wells
Tyson Wash WQARF Site, Quartzsite, Arizona**

Well ID (ADWR No.)	Date Sampled	Pump Intake Depth (ft)	Sample Flow Rate (gpm)	Volatile Organic Compound Concentrations (µg/l)			
				PCE	TCE	cis-1,2-DCE	1,1-DCE
INJ-2 (55-205421)	10/03/05	60	0.044	8.0	<1	<1	<2
	12/06/05	60	0.044	1.7	<1	<1	<2
	03/02/06	60	0.050	6.1	<1	<1	<2
	05/23/06	60	0.046	<1	<1	<1	<2
	09/12/06	60	0.046	<1	<1	<1	<2
	11/29/06	60	0.046	<1	<1	<1	<2
	02/28/07	60	0.046	<1	<1	<1	<2
	05/17/07	60	0.046	<1	<1	<1	<2
ADEQ AWQS				5	5	70	7

Notes:

µg/l - micrograms per liter

PCE - tetrachloroethene

TCE - trichloroethene

cis-1,2-DCE - cis-1,2-dichloroethene

1,1-DCE - 1,1-dichloroethene

-- - data unavailable

EPA - U.S. Environmental Protection Agency

ADEQ - Arizona Department of Environmental Quality

AWQS - Aquifer Water Quality Standards

NE - Not Established

NA - Not Analyzed

D - Duplicate Sample

¹ - Well QMW-6 has been inaccessible since March 2002 due to road construction activity. Abandoned 1/22.

Checked by: _____

**Table 3. Results of Groundwater Sample Analyses - Domestic Wells
Tyson Wash WQARF Site, Quartzsite, Arizona**

Well ID (ADWR Number)	Date Sampled	EPA Method 8260B/524.2 ¹ (µg/L)			
		PCE	TCE	cis-1,2-DCE	1,1-DCE
Cast					
B-1² (55-540500)	08/08/95	1.4	<0.5	--	--
	11/04/99	10	0.58	<0.4	<0.4
	05/12/00	11	0.7	<0.5	<0.5
	08/10/00	12	0.84	<0.5	<0.5
	10/31/00	11	0.88	<0.5	<0.5
	02/13/01	9	0.82	<0.5	<0.5
	05/08/01	8.2	0.70	<0.5	<0.5
B-2² (55-531202)	08/08/95	20	0.8	--	--
	08/08/95 D	19	0.8	--	--
	07/30/97	1.3	<0.5	--	--
	10/29/97	4.1	<0.5	--	--
	05/13/98	22	0.96	--	--
	08/12/98	25	<0.5	--	--
	11/16/98	22	0.54	--	--
	02/22/99	37	1.6	--	--
	05/27/99	42	2.1	--	--
B-3 (deep well) (55-526878)	02/07/00	<2	<2	<2	<1
	05/12/00	<0.5	<0.5	<0.5	<0.5
	08/10/00	<0.5	<0.5	<0.5	<0.5
	10/31/00	<0.5	<0.5	<0.5	<0.5
	02/13/01	<0.5	<0.5	<0.5	<0.5
	05/08/01	<0.5	<0.5	<0.5	<0.5
	08/15/01	NA	NA	NA	NA
	11/21/01	<0.5	<0.5	<0.5	<0.5
	11/21/01 D	<0.5	<0.5	<0.5	<0.5
	03/28/02	<0.5	<0.5	<0.5	<0.5
	02/12/03	<2	<2	<2	<5
	05/14/03	NA	NA	NA	NA
	12/03/03	<2	<2	<2	<5
	03/03/04	<2	<2	<2	<5
	06/09/04	<1	<1	<1	<2
	09/22/04	<1	<1	<1	<2
	12/08/04	<1	<1	<1	<1
02/17/05	<1	<1	<1	<1	
05/25/05	<1	<1	<1	<2	
10/03/05	sampling attempted, pump was inoperabl				
12/07/05	sampling attempted, pump was inoperabl				
03/02/06	sampling attempted, pump was inoperabl				
05/22/06	pump inoperable, well is removed from sampling prograr				
B-4² (55-530652)	08/08/95	<0.5	<0.5	--	--
	08/30/95	0.8	<0.5	--	--
	11/04/99	<0.4	<0.4	<0.4	<0.4
Parsons (55-630831)	10/29/97	<0.5	<0.5	--	--
	05/27/99	<0.4	<0.4	--	--
	05/12/00	<0.5	<0.5	<0.5	<0.5
	10/31/00	<0.5	<0.5	<0.5	<0.5
	02/13/01	<0.5	<0.5	<0.5	<0.5
	05/08/01	<0.5	<0.5	<0.5	<0.5
	08/15/01	NA	NA	<0.5	NA
	11/21/01	<0.5	<0.5	<0.5	<0.5
	03/28/02	<0.5	<0.5	<0.5	<0.5
	02/18/03	<2	<2	<2	<5
	05/14/03	<2	<2	<2	<5
	09/04/03	<2	<2	<2	<5
	12/04/03	<2	<2	<2	<5
	03/03/04	<2	<2	<2	<5
	06/09/04	<1	<1	<1	<2
	09/22/04	<1	<1	<1	<2
	12/07/04	<1	<1	<1	<1
	02/16/05	<1	<1	<1	<1
	05/24/05	<1	<1	<1	<2
09/21/05	<1	<1	<1	<2	
12/07/05	<1	<1	<1	<2	
03/02/06	<1	<1	<1	<2	
05/22/06	<1	<1	<1	<2	
09/14/06	<1	<1	<1	<2	
ADEQ AWQS		5	5	70	7

See Page 5 for Notes

**Table 3. Results of Groundwater Sample Analyses - Domestic Wells
Tyson Wash WQARF Site, Quartzsite, Arizona**

Well ID (ADWR Number)	Date Sampled	EPA Method 8260B/524.2 ¹ (µg/L)			
		PCE	TCE	cis-1,2-DCE	1,1-DCE
Parsons (55-630831)	11/28/06	<1	<1	<1	<2
	02/27/07	<1	<1	<1	<2
	05/15/07	<1	<1	<1	<2
Adams					
North (55-644019)	05/27/99	<0.4	<0.4	--	--
	05/12/00	<0.5	<0.5	<0.5	<0.5
	08/10/00	<0.5	<0.5	<0.5	<0.5
	10/31/00	<0.5	<0.5	<0.5	<0.5
	02/13/01	<0.5	<0.5	<0.5	<0.5
	05/08/01	<0.5	<0.5	<0.5	<0.5
	08/15/01	NA	NA	NA	NA
	11/21/01	<0.5	<0.5	<0.5	<0.5
	03/28/02	0.64	<0.5	<0.5	<0.5
	02/13/03	<2	<2	<2	<5
	05/14/03	<2	<2	<2	<5
	09/04/03	<2	<2	<2	<5
	12/04/03	<2	<2	<2	<5
	03/03/04	<2	<2	<2	<5
	06/09/04	1.2	<1	<1	<2
	09/22/04	1.1	<1	<1	<2
	12/08/04	1.4	<1	<1	<1
	02/18/05	1.3	<1	<1	<1
	05/24/05	1.0	<1	<1	<2
	09/21/05	1.1	<1	<1	<2
	12/07/05	1.1	<1	<1	<2
	03/02/06	1.0	<1	<1	<2
	05/22/06	<1.0	<1	<1	<2
09/14/06	1.2	<1	<1	<2	
11/28/06	1.1	<1	<1	<2	
02/27/07	<1	<1	<1	<2	
05/17/07	1.3	<1	<1	<2	
South (55-644020)	05/12/00	<0.5	<0.5	<0.5	<0.5
	08/10/00	<0.5	<0.5	<0.5	<0.5
	10/31/00	<0.5	<0.5	<0.5	<0.5
	02/13/01	<0.5	<0.5	<0.5	<0.5
	05/08/01	<0.5	<0.5	<0.5	<0.5
	08/15/01	NA	NA	<0.5	NA
	11/21/01	<0.5	<0.5	<0.5	<0.5
	03/28/02	0.61	<0.5	<0.5	<0.5
	02/13/03	<2	<2	<2	<5
	05/14/03	<2	<2	<2	<5
	09/04/03	<2	<2	<2	<5
	12/04/03	<2	<2	<2	<5
	03/03/04	<2	<2	<2	<5
	06/09/04	1.2	<1	<1	<2
	09/22/04	<1	<1	<1	<2
	12/08/04	1.2	<1	<1	<1
	02/18/05	1.4	<1	<1	<1
	05/24/05	<1	<1	<1	<2
	09/21/05	1.1	<1	<1	<2
	12/07/05	<1	<1	<1	<2
	03/02/06	<1	<1	<1	<2
	05/22/06	<1	<1	<1	<2
	09/14/06	1.3	<1	<1	<2
11/28/06	<1	<1	<1	<2	
02/27/07	1.3	<1	<1	<2	
05/17/07	1.5	<1	<1	<2	
Rhoades West (55-526314)	10/29/97	4.9	<0.5	--	--
	02/22/99	5.1	<0.5	--	--
	05/14/99	4.4	<0.4	--	--
	05/27/99	5.1	<0.4	--	--
	10/31/00	9.4	<0.5	<0.5	<0.5
	02/13/01	8.0	<0.5	<0.5	<0.5
	05/08/01	8.1	<0.5	<0.5	<0.5
	05/08/01 D	7.9	<0.5	<0.5	<0.5
	08/15/01	10.0	<0.5	<0.5	<0.5
	11/21/01	8.3	<0.5	<0.5	<0.5
	03/28/02	5.5	<0.5	<0.5	<0.5
	03/28/02 D	5.9	<0.5	<0.5	<0.5
	02/18/03	3.3	<2	<2	<5
ADEQ AWQS		5	5	70	7

See Page 5 for Notes

**Table 3. Results of Groundwater Sample Analyses - Domestic Wells
Tyson Wash WQARF Site, Quartzsite, Arizona**

Well ID (ADWR Number)	Date Sampled	EPA Method 8260B/524.2 ¹ (µg/L)			
		PCE	TCE	cis-1,2-DCE	1,1-DCE
Rhoades West (55-526314)	05/15/03	3.2	<2	<2	<5
	09/04/03	3.2	<2	<2	<5
	09/04/03 D	3.0	<2	<2	<5
	12/03/03	5.4	<2	<2	<5
	12/03/03 D	5.0	<2	<2	<5
	03/03/04	4.3	<2	<2	<5
	03/03/04 D	4.5	<2	<2	<5
	06/09/04	6.4	<1	<1	<2
	6/9/04 D	6.6	<1	<1	<2
	09/22/04	5.2	<1	<1	<2
	9/22/04 D	5.6	<1	<1	<2
	12/07/04	7.7	<1	<1	<1
	12/07/04 D	7.8	<1	<1	<1
	02/18/05	5.5	<1	<1	<1
	2/18/05 D	4.8	<1	<1	<1
	05/24/05	4.3	<1	<1	<1
	5/24/2005 D	4.3	<1	<1	<2
	09/21/05	6.5	<1	<1	<2
	9/21/05 D	6.1	<1	<1	<2
	12/07/05	3.4	<1	<1	<2
	12/07/05 D	3.1	<1	<1	<2
	03/02/06	3.0	<1	<1	<2
	03/02/06 D	3.0	<1	<1	<2
	05/22/06	3.7	<1	<1	<2
	5/22/06 D	3.8	<1	<1	<2
	09/14/06	4.7	<1	<1	<2
	9/14/06 D	5.0	<1	<1	<2
11/28/06	6.1	<1	<1	<2	
11/28/06 D	5.7	<1	<1	<2	
03/01/07	6.6	<1	<1	<2	
3/01/07 D	5.9	<1	<1	<2	
05/15/07	6.9	<1	<1	<2	
5/15/07 D	6.6	<1	<1	<2	
Kauffman ²	08/12/98	<1	<1	--	--
	05/27/99	29	<1	--	--
	05/08/01	11	<1	<0.5	<0.5
Welcome RV (55-541533)	11/09/95	200	6.2	--	--
	11/9/95 D	180	7	--	--
	11/04/99	74	<4	<4	<4
	11/04/99 D	79	<4	<4	<4
	04/03/00	120	5.7	<0.5	<0.5
	08/10/00	NA	NA	<0.5	NA
	11/16/00	100	4.7	<0.5	<0.5
	11/16/00 D	110	4.9	<0.5	<0.5
	02/13/01	130	5.0	<0.5	<0.5
	05/08/01	NA	NA	<0.5	NA
	08/15/01	NA	NA	<0.5	NA
	12/14/01	120	5.5	<0.5	<0.5
	03/28/02	NA	NA	<0.5	NA
	02/12/03	160	4.5	<2	<5
	02/12/03	160	4.6	<2	<5
	05/14/03	NA	NA	<0.5	NA
	11/18/03	100	3.8	<2	<5
	01/08/04	92	3.0	<2	<5
	02/10/04	91	3.0	<2	<5
	02/10/04 ³	79	2.9	<0.5	<0.5
	03/03/04	90	2.9	<2	<5
	11/22/2004 ⁴	7.8	<1	<1	<2
	12/08/04	27.3	<1	<1	<1
	02/16/05	30	<1	<1	<1
12/07/05	12	<1	<1	<2	
03/02/06	20	1.0	<1	<2	
11/28/06	60	2.9	<1	<2	
03/01/07	12	<1	<1	<2	
York (55-600695)	04/03/98	<0.5	<0.5	--	--
	05/27/99	<0.4	<0.4	--	--
	11/04/99	<0.4	<0.4	<4	<0.4
	05/12/00	<0.5	<0.5	<4	<0.5
	08/10/00	<0.5	<0.5	<0.5	<0.5
ADEQ AWQS		5	5	70	7

See Page 5 for Notes

**Table 3. Results of Groundwater Sample Analyses - Domestic Wells
Tyson Wash WQARF Site, Quartzsite, Arizona**

Well ID (ADWR Number)	Date Sampled	EPA Method 8260B/524.2 ¹ (µg/L)			
		PCE	TCE	cis-1,2-DCE	1,1-DCE
York (55-600695)	10/31/00	<0.5	<0.5	<0.5	<0.5
	02/13/01	<0.5	<0.5	<0.5	<0.5
	05/08/01	<0.5	<0.5	<0.5	<0.5
	05/08/01 D	<0.5	<0.5	<0.5	<0.5
	08/15/01	<0.5	<0.5	<0.5	<0.5
	11/21/01	<0.5	<0.5	<0.5	<0.5
	03/27/02	<0.5	<0.5	<0.5	<0.5
	02/13/03	<2	<2	<2	<5
	05/14/03	NA	NA	NA	NA
	09/04/03	<2	<2	<2	<5
	12/04/03	<2	<2	<2	<5
	01/08/04	<2	<2	<2	<5
	03/03/04	<2	<2	<2	<5
	06/09/04	3.7	<1	<1	<2
	09/22/04	1.4	<1	<1	<2
	12/08/04	2.5	<1	<1	<1
	02/18/05	1.6	<1	<1	<1
	05/24/05	4.3	<1	<1	<2
	09/21/05	4	<1	<1	<2
	12/07/05	4.2	<1	<1	<2
03/02/06	3.8	<1	<1	<2	
05/22/06	7.2	<1	<1	<2	
09/14/06	3.1	<1	<1	<2	
11/28/06	4.1	<1	<1	<2	
03/01/07	3.4	<1	<1	<2	
05/15/07	5.8	<1	<1	<2	
La Casa Del Rancho Restaurant					
East	11/04/99	1.5	<0.4	<0.4	<0.4
	05/12/00	NA	NA	<0.5	NA
	08/10/00	<0.5	<0.5	<0.5	<0.5
	10/31/00	<0.5	<0.5	<0.5	<0.5
	02/13/01	<0.5	<0.5	<0.5	<0.5
	05/08/01	<0.5	<0.5	<0.5	<0.5
	08/15/01	<0.5	<0.5	<0.5	<0.5
	11/21/01	<0.5	<0.5	<0.5	<0.5
	03/28/02	<0.5	<0.5	<0.5	<0.5
	02/12/03	NA	NA	NA	NA
	05/14/03	<2	<2	<2	<5
	West	11/04/99	4	<0.4	<0.4
05/12/00		5.1	<0.5	<0.5	<0.5
08/10/00		5.9	<0.5	<0.5	<0.5
11/16/00		7.6	<0.5	<0.5	<0.5
02/13/01		9	<0.5	<0.5	<0.5
05/08/01		8.6	<0.5	<0.5	<0.5
08/15/01		NA	NA	<0.5	NA
11/21/01		9.8	<0.5	<0.5	<0.5
03/28/02		<0.5	<0.5	<0.5	<0.5
04/19/02		10	<0.5	<0.5	<0.5
02/12/03		<2	<2	<2	<5
05/14/03		14	<2	<2	<5
Joyce's Craft Supplies	01/08/04	<2	<2	<2	<5
Mark's Family Restaurant ² (Formerly The Beauty Shop)	11/09/95	<0.5	<0.5	--	<0.5
	11/04/99	<0.4	<0.4	<0.4	<0.4
Post Office ²	08/08/95	8.5	<0.5	--	<0.5
	11/04/99	21	<0.8	<0.8	<0.8

**Table 3. Results of Groundwater Sample Analyses - Domestic Wells
Tyson Wash WQARF Site, Quartzsite, Arizona**

Well ID (ADWR Number)	Date Sampled	EPA Method 8260B/524.2 ¹ (µg/L)			
		PCE	TCE	cis-1,2-DCE	1,1-DCE
Eric's RV Repair ² (55-514430)	02/07/00	0.5	<0.5	<0.5	3
	05/12/00	<0.5	<0.5	<0.5	<0.5
	08/10/00	<0.5	<0.5	<0.5	<0.5
	10/31/00	<0.5	<0.5	<0.5	<0.5
	02/13/01	<0.5	<0.5	<0.5	<0.5
	05/08/01	<0.5	<0.5	<0.5	<0.5
ADEQ AWQS		5	5	70	7

Notes:

¹ - Samples were analyzed by U.S. EPA Method 524.2 through March 2002, and by Method 8260B thereafter

Except where indicated, samples collected after 5/99 were analyzed by Del Mar Analytica

² - Well is no longer in service

³ - Split sample analyzed by Transwest Geochem, Inc

⁴ - Sample collected by ADEQ on 11/22/04

µg/l - micrograms per liter

PCE - tetrachloroethene

TCE - trichloroethene

1,1-DCE - 1,1-dichloroethene

MTBE - methyl-tert-butyl-ethe

cis-1,2-DCE - cis-1,2-dichloroethene

NA - Not analyzed during this sampling ever

EPA - U.S. Environmental Protection Agency;

ADEQ - Arizona Department of Environmental Quality

AWQS - Aquifer Water Quality Standard

NE - Not Established

NA - Not Analyzed

D - Duplicate Sample

-- - data unavailable

Checked by: JNC _____

APPENDICES

APPENDIX A

EXPANDED REMEDIATION SYSTEM MODELING RESULTS

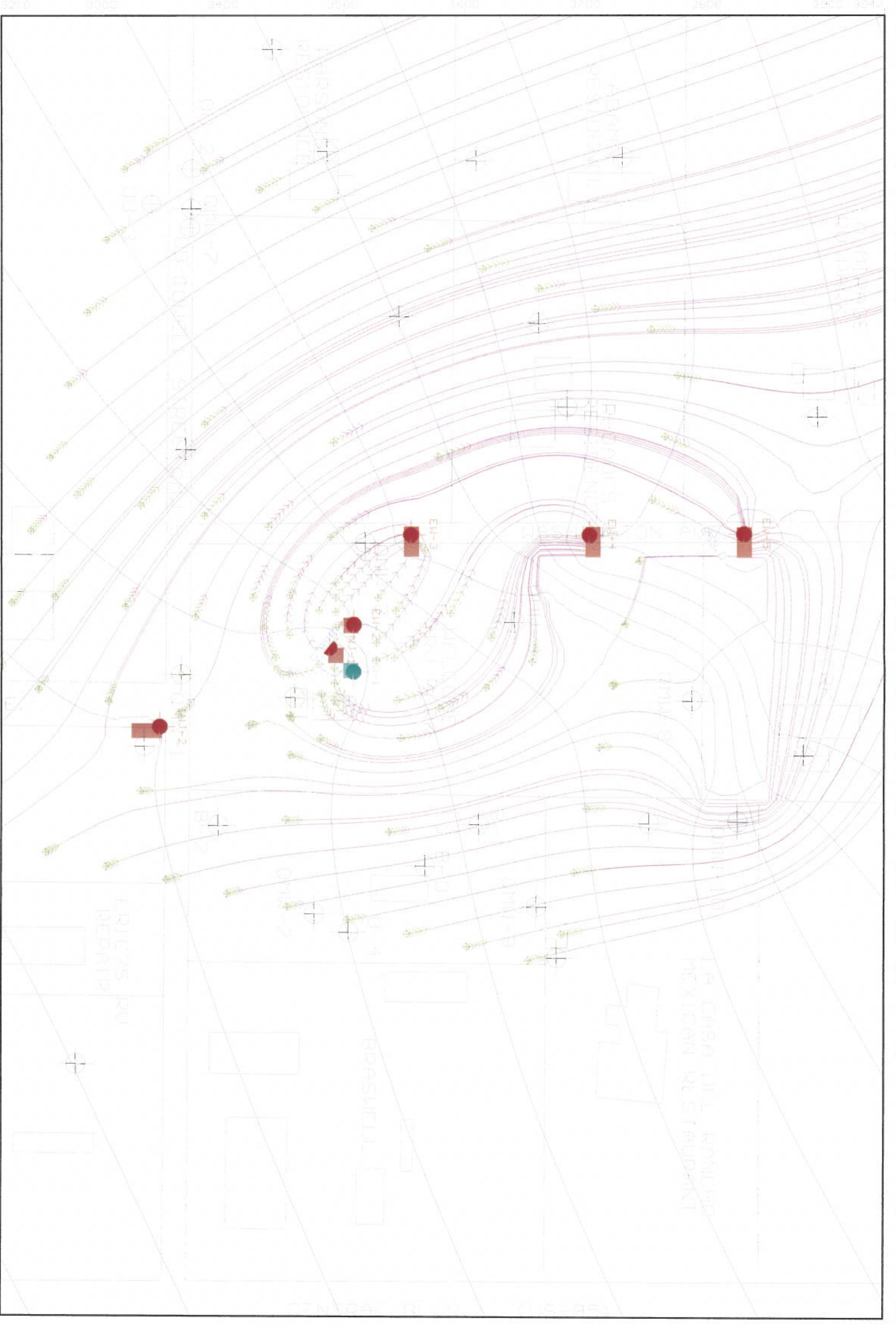

MACTEC ENGINEERING AND CONSULTING
 Project: Tyson Wash Water
 Description: NOV2005 MODPH. 1B
 Modeler: Paul Sotelo
 10 Nov 05

Visited MOOREHEAD 4-2-02, (C) 1995-1999
 Waterloo Hydrogeologic, Inc.
 NS 98 NW 98 N1/2 J
 Current Layer 1

APPENDIX B

REMEDIATION SYSTEM CONSTRUCTION SCHEMATICS

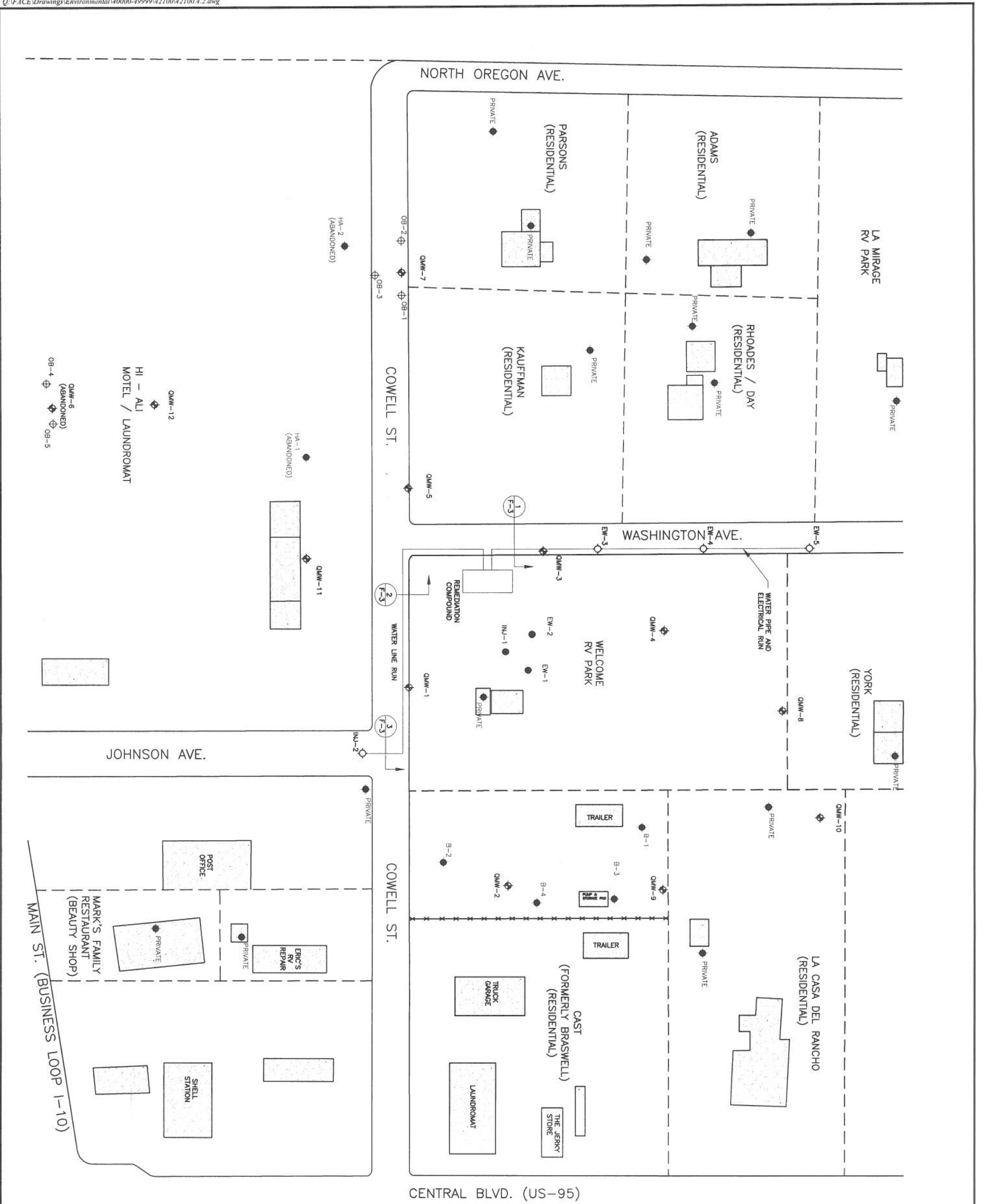

EXPLANATION

- QMW-2 ◊ MONITORING WELL
- B-4 ● DOMESTIC WELL
- OB-4 ◊ OBSERVATION WELL
- EW-1 ● WATER TREATMENT EXTRACTION AND INJECTION WELLS
- ◊ NEWLY INSTALLED WATER TREATMENT EXTRACTION AND INJECTION WELLS

GENERAL CONSTRUCTION NOTES:

1. ALL WORK SHALL BE COMPLETED IN ACCORDANCE WITH ALL STATE AND LOCAL BUILDING CODES.
2. MACTEC SHALL OBTAIN NECESSARY PERMITS AND INSPECTIONS WHERE REQUIRED
3. ALL WORK SHALL COMPLY WITH "OSHA" REGULATIONS
4. MACTEC SHALL BE RESPONSIBLE FOR VERIFYING ALL FIELD DIMENSIONS BEFORE COMMENCEMENT OF WORK.
5. MACTEC SHALL BE RESPONSIBLE FOR IDENTIFYING ALL CONFLICTING UTILITIES WITH UTILITY OWNERS BEFORE BEGINNING OF WORK. CONTRACTOR SHALL REPAIR OR REPLACE AT HIS OWN COST, UTILITIES DAMAGED DURING THE CONSTRUCTION ACTIVITIES.
6. ERI SHALL SUPPLY ALL NECESSARY MATERIALS AND LABOR TO COMPLETE THE INSTALLATION.
7. EXCAVATION CONTRACTOR SHALL REMOVE FROM THE SITE AND DISPOSE OF EXCESS SOIL MATERIAL AND DEBRIS GENERATED FROM CONSTRUCTION ACTIVITIES.
8. ANY CONFLICTS BETWEEN THE GUIDELINES SPECIFIED IN THESE PLANS AND ACTUAL OR ANTICIPATED SITE CONDITIONS SHALL BE BROUGHT TO THE ATTENTION OF THE PROJECT MANAGER.

COWELL ST.



3630 E. WIER AVE., PHOENIX, ARIZONA 85040

SITE PLAN

SITE LOCATION: ADEQ TYSON WASH WQARF SITE QUARTZSITE, ARIZONA

DRAWN	PROJECT NO.	APPROVED	DATE	FIGURE
MDF	4972-04-2100.4.2	JNC	09/02/05	1

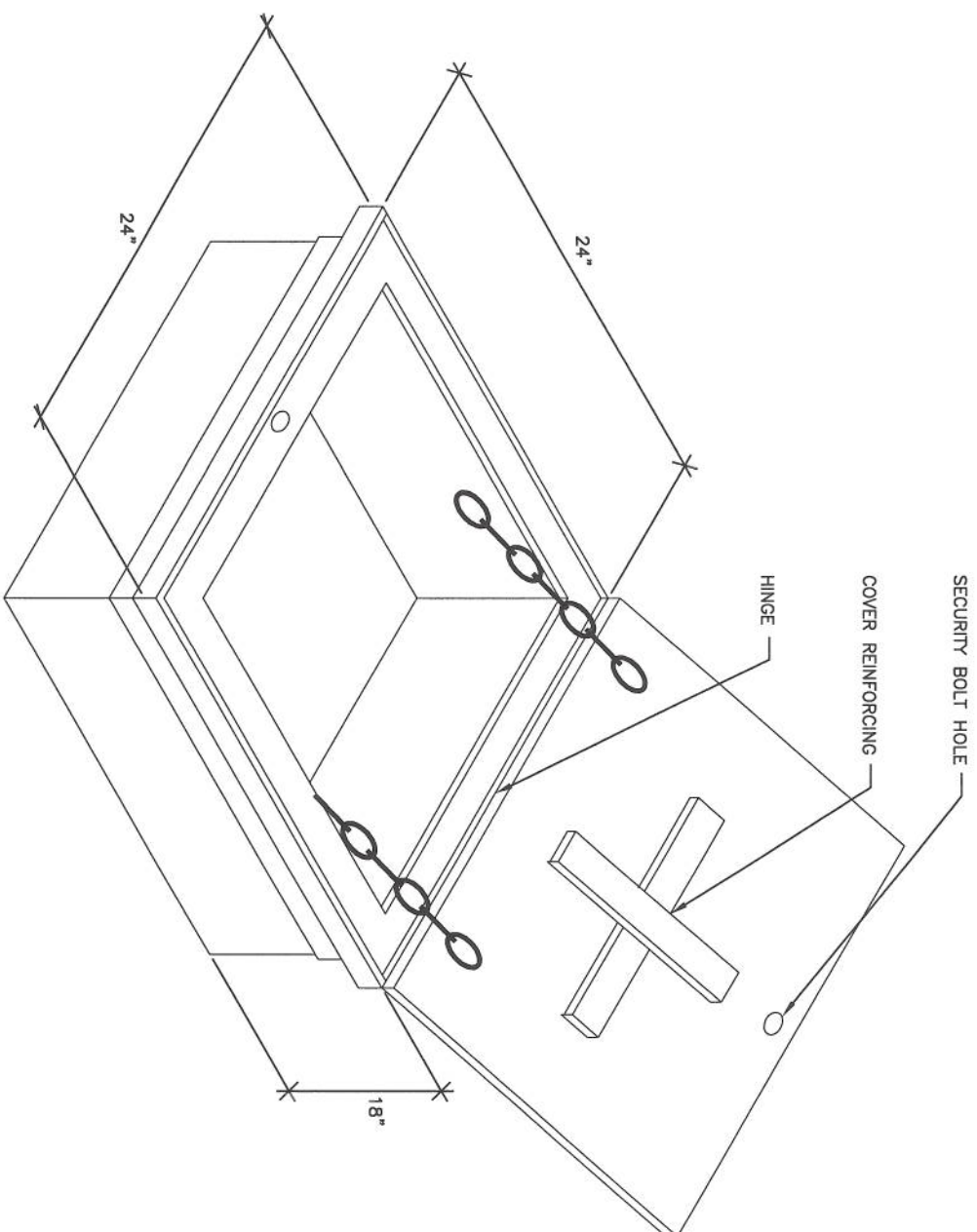
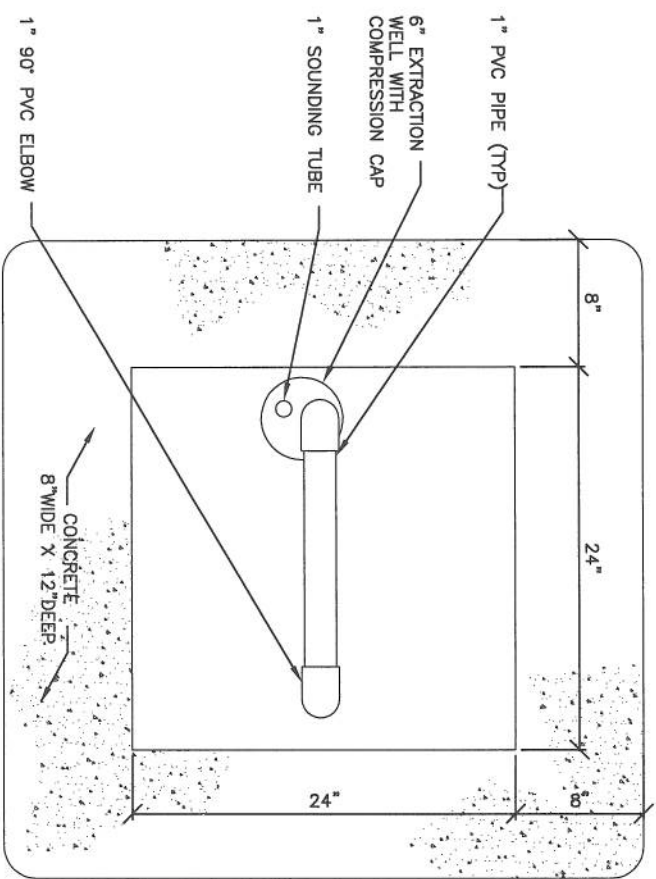
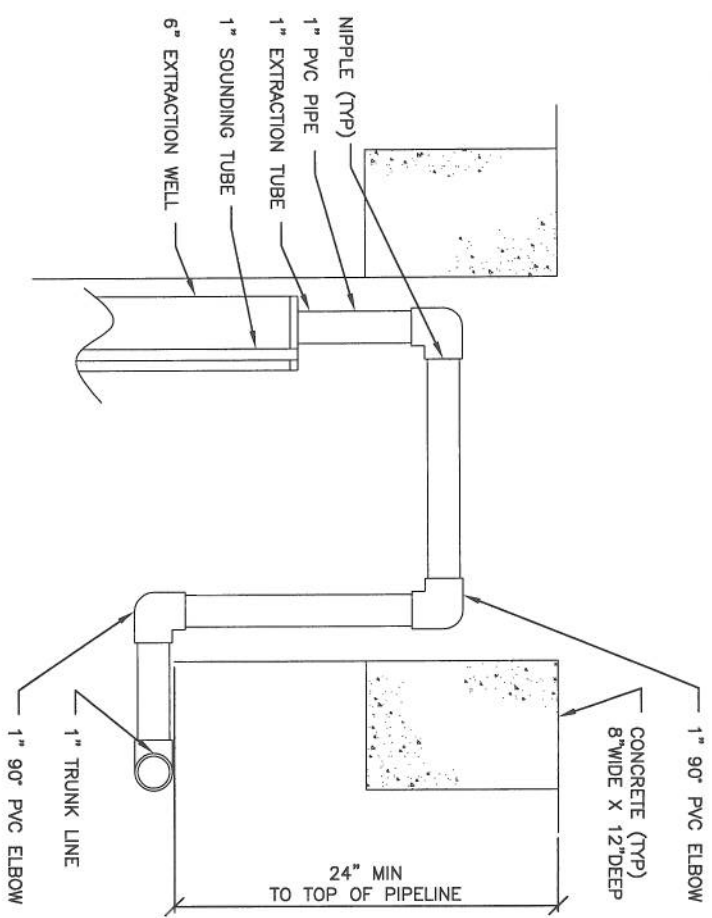

WELLHEAD & VAULT COVER
SCALE: 3/8" = 1'-0"

EXTRACTION WELL VAULT

SCALE: 1" = 1'-0"

 <p>3630 E. WIER AVE.; PHOENIX, ARIZONA 85040</p>		WELLHEAD DETAILS & ENTRANCE	
		SITE LOCATION: ADEQ TYSON WASH WOARF SITE QUARTZSITE, ARIZONA	
DRAWN	PROJECT NO.	APPROVED	DATE
MDF	4972-04-2100.4.2	JNC	09/02/05
FIGURE			2

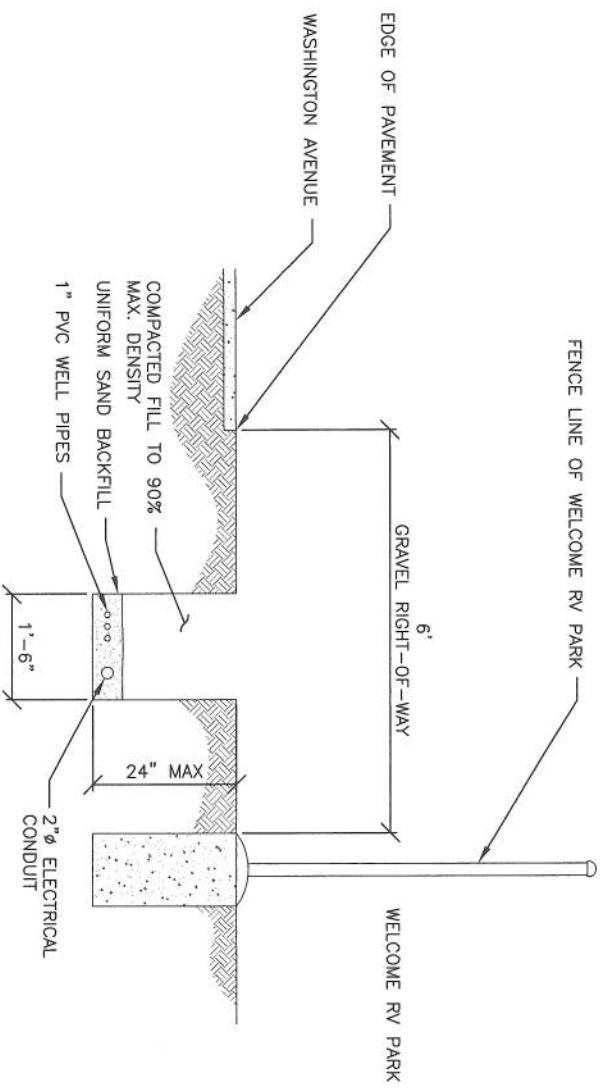

1 - EXTRACTION PIPE TRENCH DETAIL
SCALE: 3/8" = 1'-0"

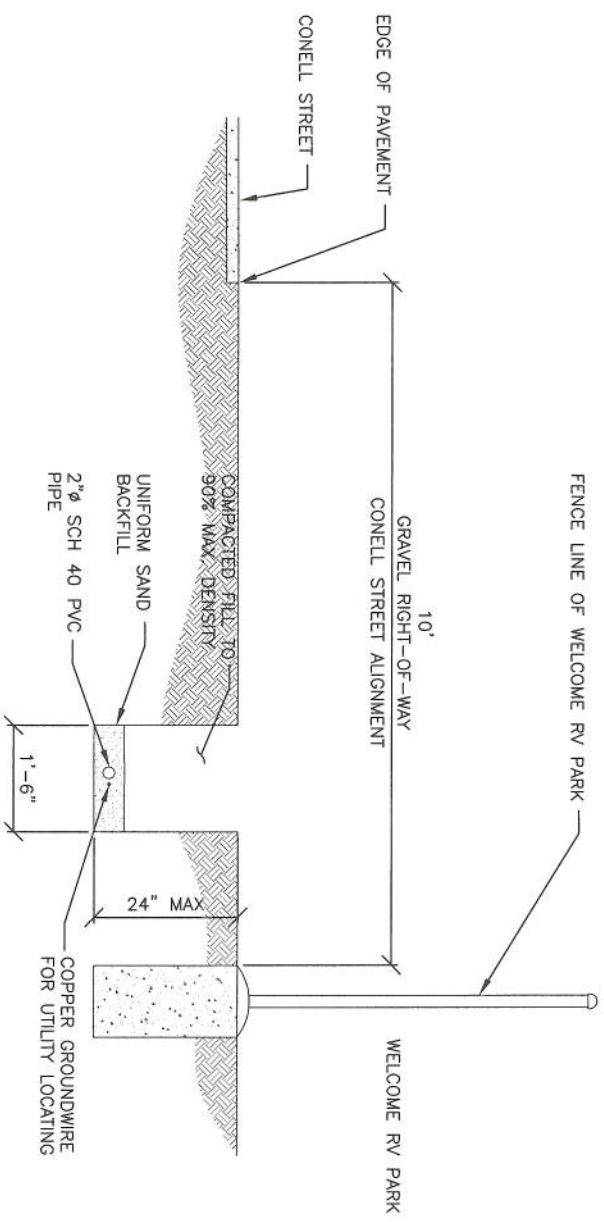

2 - INJECTION PIPE TRENCH DETAIL
SCALE: 3/8" = 1'-0"

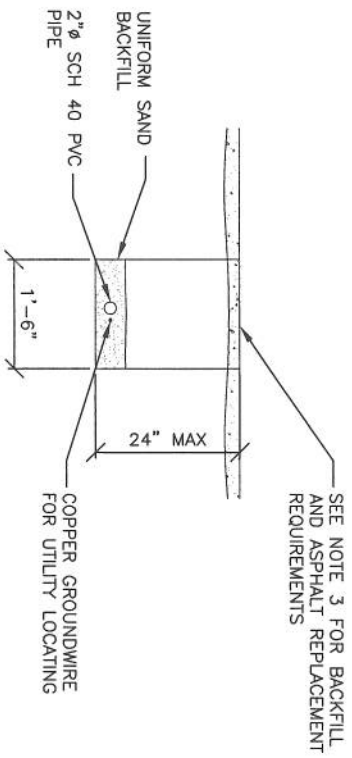

3 - COWELL STREET CROSSING
SCALE: 3/8" = 1'-0"

SEE NOTE 3 FOR BACKFILL AND ASPHALT REPLACEMENT REQUIREMENTS

- NOTES:
1. TRENCH LOCATION ON RIGHT-OF-WAY CAN BE ADJUSTED LATERSALLY TO AVOID CONFLICT WITH EXISTING UTILITIES
 2. PIPE MUST BE GENTLY SLOPED DOWNWARD FROM SYSTEM COMPOUND TO WELTHEAD
 3. FOR SOIL BACKFILL AND RECONSTRUCTION OF THE ASPHALT CONCRETE PAVEMENT SECTIONS THE MATERIALS, CONSTRUCTION PROCEDURES, AND OPERATIONS SHALL CONFORM TO THE FOLLOWING SECTIONS OF THE MARICOPA ASSOCIATION OF GOVERNMENTS UNIFORM STANDARD SPECIFICATIONS FOR PUBLIC WORKS CONSTRUCTION: SECTION 206 FOR EXCAVATION AND BACKFILL, SECTION 301 FOR SUBGRADE PREPARATION, SECTION 310 FOR AGGREGATE BASE COURSE, AND SECTION 321 FOR ASPHALT CONCRETE PAVEMENT.
- THE THICKNESS OF THE REPLACEMENT AGGREGATE BASE COURSE AND ASPHALT CONCRETE PAVEMENT SECTIONS SHALL MATCH THE EXISTING PAVEMENT SECTIONS WITHIN THE ROADWAY IMPROVEMENT AREA.



3630 E. WIER AVE., PHOENIX, ARIZONA 85040

TRENCH DETAILS

SITE LOCATION: ADEQ TYSON WASH WOARF SITE QUARTZSITE, ARIZONA

DRAWN	PROJECT NO.	APPROVED	DATE	FIGURE
MDF	4972-04-2100.4.2	JNC	09/02/05	3

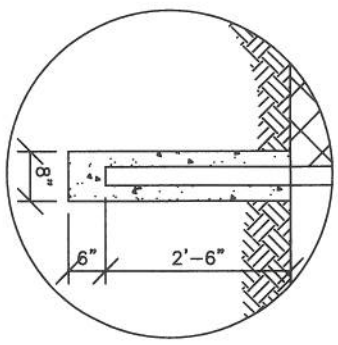
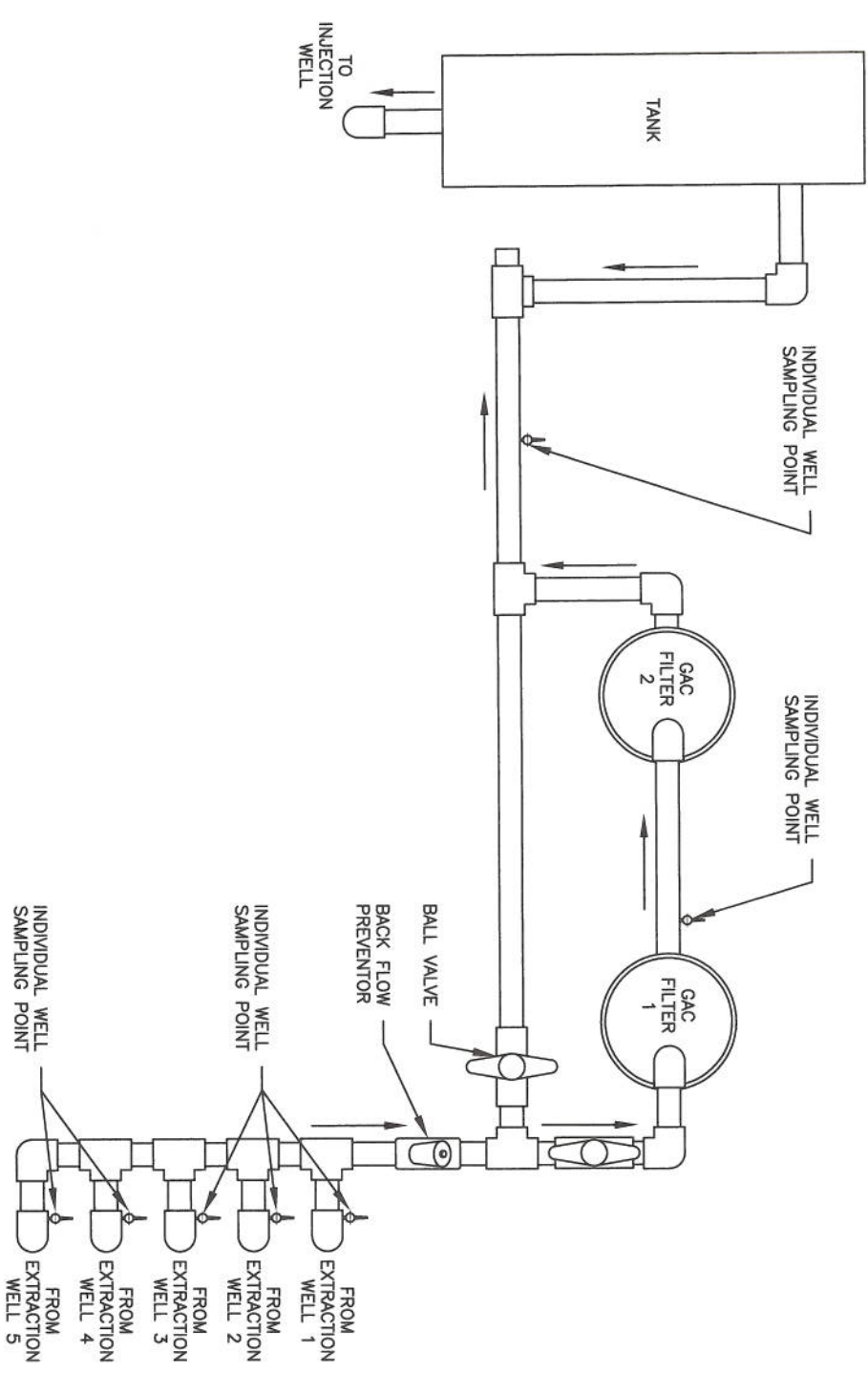

FOOTING DETAIL (TYP)
SCALE: 3/8" = 1'-0"

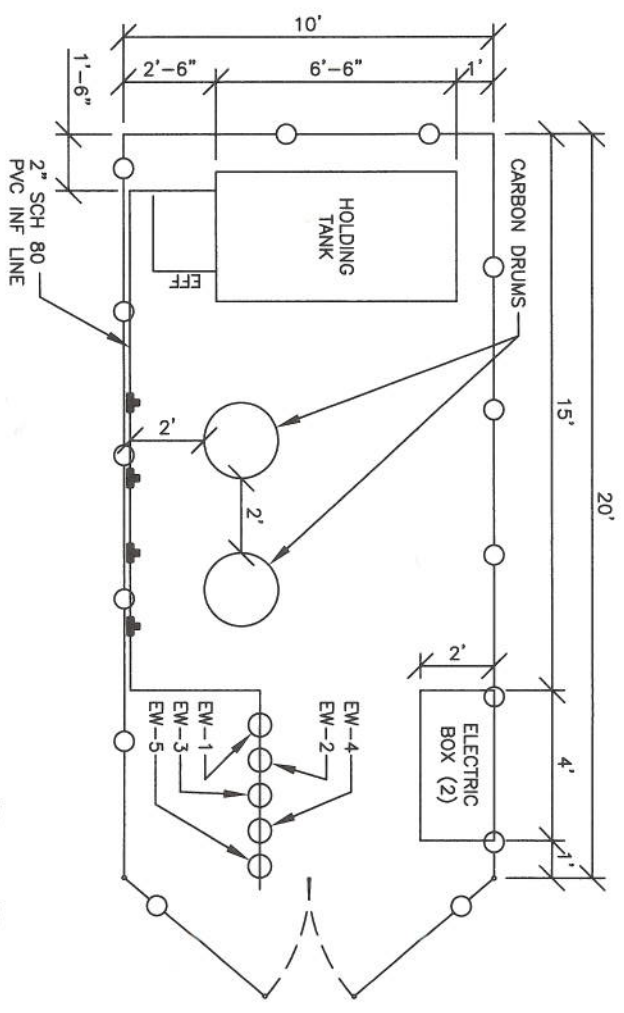

WATER TREATMENT COMPOUND
SCALE: 3/16" = 1'-0"

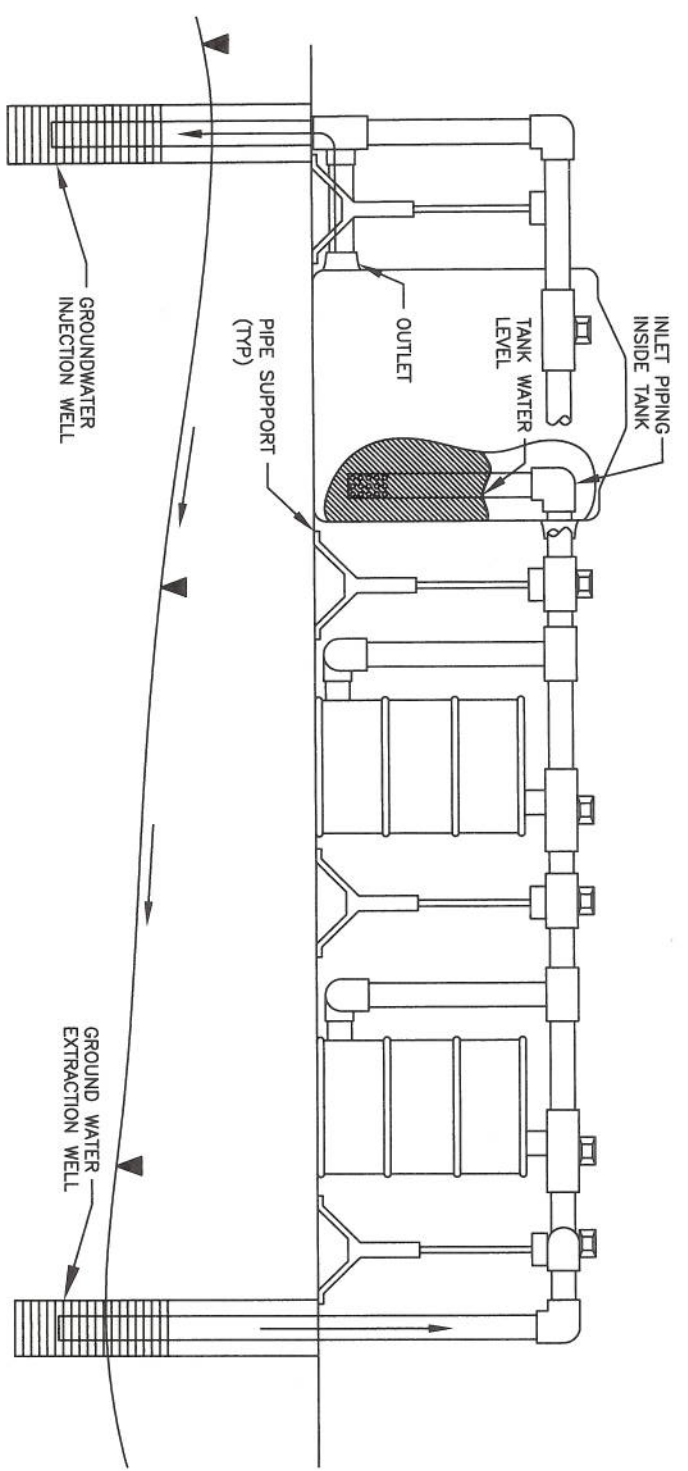

ABOVE GROUND TANK & MANIFOLD CONFIGURATION
SCALE: 3/16" = 1'-0"

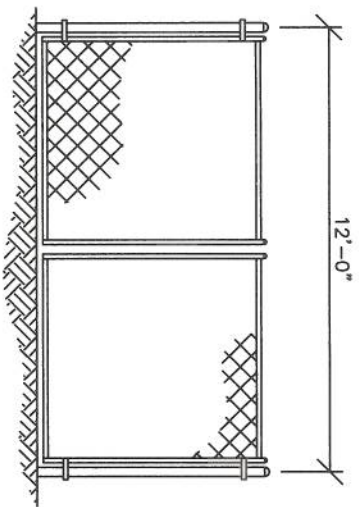

FRONT ELEVATION

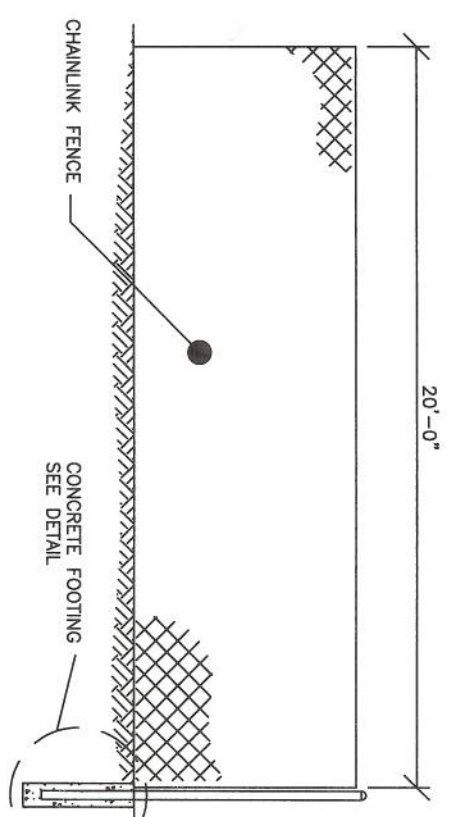

SIDE ELEVATION

REMEDIATION FENCE
SCALE: 3/16" = 1'-0"

ENCLOSURE DIAGRAM



3630 E. WIER AVE.; PHOENIX, ARIZONA 85040

SITE LOCATION: ADEQ TYSON WASH WQARF SITE QUARTZSITE, ARIZONA

DRAWN	PROJECT NO.	APPROVED	DATE	FIGURE
CJE	4972-07-2100.6.0		07/19/07	4