

NOTICE OF FINAL RULEMAKING
TITLE 18. ENVIRONMENTAL QUALITY
CHAPTER 14. DEPARTMENT OF ENVIRONMENTAL QUALITY - PERMIT AND COMPLIANCE FEES

PREAMBLE

1. Permission to proceed with this final rulemaking was granted under A.R.S. § 41-1039 by the governor on:

March 5, 2024

2. Article, Part, or Section Affected (as applicable)

Rulemaking Action

R18-14-101

Amend

R18-14-102

Amend

R18-14-104

Amend

Table 1

Amend

3. Citations to the agency's statutory rulemaking authority to include the authorizing statute (general) and the implementing statute (specific):

Authorizing statute: A.R.S. §§ 49-104(A)(1), (7); 49-203(A)(7), (9), (10)

Implementing statute: A.R.S. § 49-211

4. The effective date of the rule:

This rule shall become effective immediately after a certified original of the rule and preamble are filed with the Office of the Secretary of State pursuant to A.R.S. § 41-1032(A). The effective date is March 4, 2025.

a. If the agency selected a date earlier than the 60-day effective date as specified in A.R.S. § 41-1032(A), include the earlier date and state the reason the agency selected the earlier effective date as provided in A.R.S. § 41-1032(A)(1) through (5):

The rule shall be effective on March 4, 2025. ADEQ selected this date pursuant to A.R.S. § 41-1032(A)(2) in order “to avoid a violation of ... state law, if the need for an immediate effective date is not created due to the agency’s delay or inaction”.

A.R.S. § 49-211 requires ADEQ to, “[o]n or before December 31, 2024 ... adopt all rules necessary to establish and implement a direct potable reuse of treated wastewater program [A.K.A. - AWP regulatory program], including rules establishing permitting standards and a permit application process.”

While an immediate effective date will not avoid a violation of A.R.S. § 49-211, it serves to ameliorate the extent of the violation by establishing an effective date as close in time as possible to the statutory deadline “on or before December 31, 2024”. The Legislature charged ADEQ with the adoption of an advanced water purification program in Fall 2022, setting a justifiably aggressive deadline of December 31, 2024. Since that time, ADEQ diligently undertook an extensive program design and rule-writing approach to appropriately design the revolutionary program. Additionally, ADEQ conducted a

special stakeholder approach commensurate with the intricacies of the program, itself, with myriad stakeholder efforts outlined in Section 7 of this Notice of Final Rulemaking. This process included engagement at all phases of the project, in the program framework and guiding principle development phase to the draft rule phase, and included multiple opportunities for ADEQ to work with and educate stakeholders, receive feedback on program components, and improve the program. Arizona is one of only a handful of states with a regulatory framework for advanced water purification, and the process was, therefore, carefully conducted to best preserve the interests of the Legislature and the health of Arizonans. While ADEQ worked just as aggressively to achieve the statutory deadline, best efforts nevertheless fell a few months short. For these reasons and pursuant to A.R.S. § 41-1032(A)(2), ADEQ did not delay or fail to act in such a way that led to the need for an immediate effective date.

b. If the agency selected a date later than the 60-day effective date as specified in A.R.S. § 41-1032(A), include the later date and state the reason the agency selected the later effective date as provided in A.R.S. § 41-1032(B):

Not Applicable.

5. Citations to all related notices published in the Register as specified in R1-1-409(A) that pertain to the current record of the final rule:

Notice of Proposed Rulemaking: 30 A.A.R. 3243, Issue Date: November 1, 2024, Issue Number: 44, File Number: R24-212.

Notice of Rulemaking Docket Opening: 30 A.A.R. 2878, Issue Date: September 20, 2024, Issue Number: 38, File Number: R24, 176.

6. The agency's contact person who can answer questions about the rulemaking:

Name: Jon Rezabek
Natalie Kilker
Title: Legal Specialists
Division: Water Quality
Address: Arizona Department of Environmental Quality
1110 W. Washington Ave.
Phoenix, AZ 85007
Telephone: (602) 771-8219
Fax: (602) 771-2366
Email: reuserulemaking@azdeq.gov
Website: <https://www.azdeq.gov/awp-rulemaking>

7. An agency's justification and reason why a rule should be made, amended, repealed or renumbered, to include an explanation about the rulemaking:

Introduction:

The Arizona Department of Environmental Quality (“ADEQ”) is mandated by the Arizona Legislature, pursuant to Arizona Revised Statutes (A.R.S.) § 49-211, to “establish by rule permit fees sufficient to administer a direct potable reuse of treated wastewater program” and “adopt all rules necessary to establish and implement a direct potable reuse of treated wastewater program, including rules establishing permitting standards and a permit application process”. The statute, adopted from House Bill 2861, as enacted in the Second Regular Session on June 28, 2022, became effective on September 24, 2022. For purposes of this Notice and the final rule, the term “direct potable reuse” is synonymous with “Advanced Water Purification” (or “AWP”), as the program is now called.

ADEQ, in consideration of Arizona’s water supply needs and the Legislative mandate, interpreted A.R.S. § 49-211 as a call to establish an AWP program that is both protective of human health and the environment, as well as imposing minimum burden upon the stakeholder community in achieving that goal. The result of that effort is detailed in the final rules to be placed in the Arizona Administrative Code (A.A.C.), Title 18, Chapters 1, 5, 9 and 14, through this Notice of Final Rulemaking (NFRM) and through the simultaneously filed associated NFRMs.

Background:

Arizona faces significant water supply challenges requiring proactive approaches to conservation and stewardship, in anticipation of decreased water availability in the future. Arizona is currently experiencing a severe and sustained drought, persisting since 1994. The state has experienced an average annual precipitation of approximately 12 inches, and climate data reveals a concerning trend: a consistent reduction of 0.9 inches of rainfall per year over the past three decades (Arizona State University, 2023, Climate of Arizona, <https://azclimate.asu.edu/climate/>). As a result of the continuing mega-drought, a Drought Emergency Declaration has existed since 1999. The impacts can be felt heavily in the rural areas of the state, where alternative water supplies are generally very limited and the economy is strongly affected by drought (e.g., grazing, irrigated agriculture, recreation, forestry). Most of rural Arizona relies exclusively on groundwater as its primary water source and lacks the groundwater regulations and conservation requirements which have been present in the state’s active management areas (AMAs) and irrigation non-expansion areas (INAs). In addition to the reduced precipitation within Arizona, the Colorado River Basin is also facing decades-long drought conditions, which have led to historically low water levels in Colorado River system reservoirs. As a result, Arizona has implemented measures to reduce its consumption of Colorado River water. The Lower Colorado River Basin first experienced a Tier 1 Shortage as agreed in the 2007 Interim Guidelines and the Drought Contingency Plan in 2021. In 2022, Bureau of Reclamation Commissioner Camille Touton called on the Colorado River states to conserve between 2-4 million acre feet per year to address the critically low levels in Lake Powell and Lake Mead following a dire water year. Fortunately, voluntary reductions in the Lower Basin and a healthy water year 2022 averted a decline to critically low elevations. However, as the Basin States look ahead, climate projections and historical

trends indicate that the Basin is likely to face increasing average temperatures and reduced precipitation in the coming years. Arizonans will likely be called upon to live with further reduced Colorado River supplies for the foreseeable future as the next set of operational guidelines for the Colorado River are finalized.

Beyond the shrinking water supply, economic growth presents water providers with formidable challenges in meeting demand. As water-intensive industries relocate to Arizona, industrial water demands may increase. Furthermore, there may be challenges with maintaining the necessary housing growth due to the release of the new models of groundwater conditions in the Phoenix and Pinal AMAs. The results of the groundwater flow model projections show that over a period of 100 years, the Phoenix AMA will experience 4.86 million acre-feet (maf) of unmet demand for groundwater supplies and the Pinal AMA will experience 8.1 maf of unmet demand for groundwater supplies, given current conditions. In keeping with these findings of unmet demand, the State will not approve new determinations of Assured Water Supply within the Phoenix and Pinal AMAs based on groundwater supplies. This will lead to an increased competition for limited alternative water supplies. As growth continues, there will be an increasing need for sustainable and innovative water resource management strategies to accommodate the state's evolving needs.

What is AWP?

Advanced Water Purification (AWP) is defined as the treatment and distribution of a municipal wastewater stream for use as potable water without the use or with limited use of an environmental buffer (US EPA, 2017, Potable Reuse Compendium). AWP has been shown to be a safe and effective source of potable water over decades of implementation in projects that have been installed worldwide at facilities in Big Spring, Texas (2013); Wichita Falls, Texas (2014); Namibia (1968 and 2002); Singapore (2019); and South Africa (2011) (Lahnsteiner, J., Van Rensburg, P., & Esterhuizen, J., 2018, Direct potable reuse—a feasible water management option. *Journal of Water Reuse and Desalination*, 8(1), 14-28).

AWP applications typically consist of a conventional water reclamation facility (WRF) or wastewater treatment plant (WWTP) that performs solids, carbon, nutrient, and pathogen removal and an advanced water treatment facility (AWTF) that provides additional pathogen and trace chemical removal. An AWTF is a utility or treatment plant where recycled wastewater is treated to produce purified water to meet specific AWP requirements. AWTFs use a multi-barrier approach where several redundant unit processes in series are installed to treat WRF effluent to potable water standards. Depending on the site-specific infrastructure configuration and treatment capabilities, the AWTF effluent may be introduced into several different locations of the potable water treatment and distribution system to be reused: (i) in the intake to the existing drinking water treatment facility (DWTF); (ii) after the DWTF and prior to the potable water distribution system; or (iii) Directly into the potable water distribution system.

Evolution of AWP in Regulations:

A predecessor to the AWP program was adopted in the A.A.C. in 2018 at R18-9-E701, including a definition of “[a]dvanced reclaimed water treatment facility” at R18-9-A701(1). An associated NFRM filed simultaneously with this NFRM will repeal these rules in their entirety to make way for the AWP program. This prior, less detailed, single-ruled program was placed in Title 18, Chapter 9, Article 7 of the A.A.C. Article 7 is entitled “Use of Recycled Water”. Part E of Article 7 was entitled “Purified Water

for Potable Use” and R18-9-E701 was entitled “Recycled Water Individual Permit for an Advanced Reclaimed Water Treatment Facility”. R18-9-E701 detailed basic requirements for an advanced reclaimed water treatment facility and, during the rule’s tenure, was used to permit one such facility. The facility was not authorized to, and did not, distribute purified water as drinking water through established conveyances or networks. As was stated above, in recent years, the Arizona Legislature determined a need for a more robust regulatory program for AWP. The Legislature passed House Bill 2861 into law in 2022, effectuating statute A.R.S. § 49-211, which led directly to the establishment of the final AWP program and the repeal of the previous program.

Associated Rulemakings:

This final rulemaking includes four NFRMs, adding, repealing or amending rules in A.A.C. Title 18. Environmental Quality:

- Chapter 1 (Department of Environmental Quality - Administration),
- Chapter 5 (Department of Environmental Quality - Environmental Reviews and Certification),
- Chapter 9 (Department of Environmental Quality - Water Pollution Control), and
- Chapter 14 (Department of Environmental Quality - Permit and Compliance Fees).

The final changes to Chapter 1 are specific to updating the Licensing Time-Frame requirements in Article 5 to account for the new AWP program. The final changes to Chapter 5 are specific to amending the Minimum Design Criteria in Article 5 to correspond with the rules in the AWP program which outline the interconnection between AWP and the Safe Drinking Water Act, specifically between AWP permitting and design requirements and those in Article 5, applicable to public water systems. The final additions, amendments and repeals to Chapter 9 are all aimed at making way for and establishing the AWP regulatory program. The final changes to Chapter 14 are specific to updating the Water Quality fees in Article 1 to accommodate the AWP program commensurate with other water quality programs.

Fees:

In accordance with the legislative mandate A.R.S. § 49-211(A), to “establish by rule permit fees sufficient to administer a direct potable reuse of treated wastewater program”, ADEQ, established specific permitting rates in rule that are sufficient for ADEQ to administer the AWP program. Like other similarly situated water programs, Arizona’s AWP program follows a fee-for-service model, deriving funding from hourly review rates for permit applications and related components as well as from annual fees. ADEQ believes the costs charged through the program are commensurate with projected costs necessary to adequately support the program, and that the final fees are fairly assessed and impose the least burden possible to parties subject to the fees.

ADEQ is proposing to update the definitions in R18-14-101 to include the “AWP” acronym and scope AWP permit and demonstration permit-related activities into the “Water Quality Protection Service” billing structure, in parallel with other water quality programs. While the existing “Water Quality Protection Service” list captures a majority of the AWP billable activities, such as pre-application and application activities, ADEQ is proposing to add a new billing item for “reviewing and commenting” on AWP permit and demonstration permit materials. This is a unique process in the final program wherein applicants may be required to submit certain plan components to the department, such as their Initial Source Water Characterization Plan, Pilot Study

Plan, and Full-Scale Verification Plan, for review and comment throughout the pre-application period (*see generally* R18-9-C813). ADEQ’s review and comment is not a licensing decision, but a method for ADEQ to collaborate with the applicant and provide feedback on foundational permit components at relevant times prior to the AWP permit application.

ADEQ is proposing to amend R18-14-102, by incorporating an AWP hourly fee into subsection (B). The hourly fee is calculated through an accounting of administrative costs such as AWP-specific program needs and salaries for technical staff, administrators, and management. ADEQ is proposing to update Table 1 under R18-14-102 by stating that there are no maximum fees for AWP. This is because the subject matter of the AWP program is vast and complicated, the state of the technology is rapidly changing, and average review times are, as of yet, unknown. ADEQ is proposing an annual fee for AWP permittees in R18-14-104 that aims to offset the direct and indirect administrative costs of the program, including items such as staff salaries and benefits, third-party professional services, staff training, operator certification administration, legal support, compliance, enforcement, database establishment and maintenance, equipment, travel, and other necessary operational expenses directly related to issuing permits and enforcing the requirements of the AWP program. ADEQ consistently utilizes this method to set and amend programmatic fees in water quality programs (*see e.g.* 17 A.A.R. 568 (2011) and 29 A.A.R. 1869 (2023)).

Notably, like other water quality program fees, as of August 4, 2023 (*see* 29 A.A.R. 1870 (2023)), AWP fees are subject to annual Consumer Price Index (CPI) adjustments. The CPI for any year is the average of the Consumer Price Index for All Urban Consumers, Phoenix-Mesa-Scottsdale, AZ, all items published by the United States Department of Labor, as of the close of the 12-month period ending on June 30 of that year, available at:

https://data.bls.gov/pdq/SurveyOutputServlet?data_tool=dropmap&series_id=CUURS48ASA0,CUUSS48ASA0.

This CPI is a better representation of Arizona’s rapidly expanding economy and population than the national CPI.

8. A reference to any study relevant to the rule that the agency reviewed and either relied on or did not rely on in its evaluation of or justification for the rule, where the public may obtain or review each study, all data underlying each study, and any analysis of each study and other supporting material:

Not Applicable.

9. A showing of good cause why the rulemaking is necessary to promote a statewide interest if the rulemaking will diminish a previous grant of authority of a political subdivision of this state:

Not Applicable.

10. A summary of the economic, small business, and consumer impact:

This Economic, Small Business, and Consumer Impact Statement has been prepared to meet the requirements of A.R.S. § 41-1055.

A. An Identification of the Rulemaking:

The rulemaking addressed by this Economic, Small Business, and Consumer Impact Statement (EIS) consists of a number of new sections, as well as amendments to existing sections, in four (4) chapters in Title 18 of the Arizona Administrative Code (A.A.C.).

Those chapters, and the respective articles affected therein, are; Chapter 1, Article 5; Chapter 5, Article 5; Chapter 9, Articles 2, 7

and 8; and Chapter 14, Article 1. The rulemaking is being conducted in order to adopt the Advanced Water Purification (AWP) regulatory program (formerly “Direct Potable Reuse” program) pursuant to statutory mandate at Arizona Revised Statutes (A.R.S.) § 49-211.

Arizona’s ongoing issues with water scarcity, combined with real concerns over meeting demand for expanding communities, highlight the need to develop additional sources of water that can meet growing municipal water demands. In response to increasing state water scarcity, the Arizona legislature mandated through A.R.S. § 49-211 that “...the [ADEQ] director shall adopt all rules necessary to establish and implement a direct potable reuse of treated wastewater program, including rules establishing permitting standards and a permit application process.” As a result, ADEQ has been charged with developing a program that allows for and regulates the advanced treatment of previously treated municipal wastewater to achieve a drinking-water-quality product, providing a new and convenient water source, known as the AWP program.

AWP is an innovative set of water treatment processes applied at an Advanced Water Treatment Facility (AWTF) that directly purify treated wastewater originating from a community’s wastewater treatment plant. This AWTF-treated water can then be either delivered to existing Drinking Water Treatment Facilities (DWTFs) for further treatment or blending or distributed directly to a drinking water distribution system. In both cases, the safeguards of the federal Safe Drinking Water Act (SDWA) continue to apply. The AWP program thus offers the potential for a new and sustainable water source that can provide a consistent supply of water for existing users and support Arizona’s future population growth and economic development.

B. A summary of the EIS:

General Impacts

The full scope of stakeholders who may incur direct impacts from this rulemaking include ADEQ, Arizona Water Provider Agencies (WPAs), Municipal governments, WPA customers, the general public, and the Arizona environment, identified, generally, here, and in more detail throughout the rest of the Economic Impact Statement (EIS) below. While not all costs and benefits are borne evenly, these are the identified groups generally impacted from the implementation of the AWP regulatory program.

ADEQ is the sole state agency responsible for the implementation and administration of the AWP program. As detailed in this EIS, impacts to ADEQ include the hiring of new staff commensurate with the expanded technical oversight necessary to administer the AWP program. However, the projected future costs to ADEQ will be offset through its fee-for-service model which places the burden for AWP program services on the applicants and permittees through application fees and annual fees, and the overall impact is therefore expected to be moderate. This approach was mandated by the Arizona Legislature through A.R.S. § 49-211, subsection (A), which states, “...[ADEQ] shall establish by rule permit fees sufficient to administer a direct potable reuse of treated wastewater program...” Therefore, the Legislature charged ADEQ with developing and administering the AWP program and required ADEQ to establish fees sufficient to maintain the program. ADEQ’s proposed fees, detailed in the Chapter 14 NFRM, were calculated to match the projected costs of the nascent program.

Next, the WPAs that elect to apply for a permit under the AWP program are affected by the capital costs of the AWP investment,

increased compliance and monitoring, and ongoing operations and maintenance responsibility. While the expected costs to participating WPAs are expected to be significant, this impact is balanced against both the voluntary and emerging natures of the AWP program. AWP is not mandated for any WPA and financial barriers to entry may be lowered over time as the program becomes more established. Additionally, Municipal governments are not delegated any administration functions of the program but may be impacted given their relationship to the WPAs in their communities. Local governments may be the WPA, and as such, face significant impacts incumbent on any WPA engaged with the AWP program.

Furthermore, WPA customers are directly impacted by the new supply, beneficially through the delivery of the additional water supply to them, and financially through impacts in water rates. Notably, these impacts are only relevant to customers of WPAs that have adopted AWP in their service area. Customers may face higher water rates as a result of AWP, however, the exact costs are not known to ADEQ as the WPA is responsible for setting reasonable rates on a case-by-case basis in consideration of their service area. The general public is generally impacted by the option of a new water supply alternative for communities, providing an overall net increase in water availability for beneficial use such as drinking. Finally, the environment is impacted, beneficially through potential decreased reliance on groundwater and surface water supplies from WPAs using AWP water as a source, but also faces impacts from changes in water use as a result of expanded, potentially lucrative use options such as reduced groundwater discharge or reclaimed water delivery.

Specific Impacts

The entity with the largest expected impact as a result of the AWP regulatory program is the WPAs. This impact is specific to capital costs, operations/maintenance cost, and permitting/compliance costs. Fundamentally the AWP program is intended to be flexible, setting minimum requirements in rule necessary for the protection of human health and the environment and in enough detail to facilitate a performance standard that can be consistently achieved by permittees under the program. However, the program leaves many details and specifics up to the discretion of the Advanced Water Purification Responsible Agency (AWPRA) as they determine what technology, treatment train configuration, etc. is best to address their treated wastewater influent, their contributing non-domestic dischargers, their AWPRA partners, etc. Therefore, the EIS cannot determine, with exact specificity, the impacts to each WPA. However, the EIS provides cost evaluations for three representative AWP projects, in an effort to provide a range of potential options. These three projects represent different treatment trains: 1) Ozone-Biologically Activated Carbon (BAC), 2) Ozone-BAC with Side-Stream Reverse Osmosis (RO), and 3) Full-Stream RO.

Upon an evaluation of these representative projects, this EIS provides expected costs related to the implementation of AWP for WPAs, enabling them to make informed decisions about whether AWP is a good option for their communities. For project 1, Ozone-BAC, the estimated costs are as follows: capital costs - \$208.0 million; annual operations and maintenance costs - \$3.3 million. For project 2, Ozone-BAC with Side-Stream RO, the estimated costs are as follows: capital costs - \$229.0 million; annual operations and maintenance costs - \$8.5 million. For project 3, Full-Stream RO, the estimated costs are as follows: capital costs - \$276.0 million; annual operations and maintenance costs - \$10.9 million.

Stakeholder Process

All stakeholders identified as entities impacted under this EIS have been subject to the AWP stakeholder engagement process. This process commenced in 2023 with a survey of the general public, a survey of more specific stakeholders, and the establishment of a Technical Advisory Group (TAG) for development of the AWP rules. The TAG consisted of experts and representatives from academia, utilities, regulatory agencies, and engineers and scientists. In combination with the additional stakeholders and conversations with expected applicants (WPAs), this effort was a comprehensive discussion on all programmatic elements, including economic impacts.

C. Identification of the persons who will be directly affected, bear the costs of, or directly benefit from the rules:

Recycled water is costly, but for some communities it may be the most cost-effective alternative for new and reliable long-term water supplies. The AWP program will operate uniquely among existing water programs as it will be state-run and has no federal equivalent. This rulemaking establishes rules, including permitting standards and a permit application process, for participating in the AWP program, a voluntary program. The decision to apply for a permit under the AWP program rests entirely with the entity wishing to pursue AWP as an addition to their drinking water portfolio.

While the AWP program is voluntary, there will be costs to each adopting entity for permitting and compliance requirements and infrastructure implementation. There may also be cascading cost impacts to other persons or groups (such as customers), but these costs will be borne throughout the water system and will be discussed in advance with stakeholders by water provider agencies.

ADEQ has identified the following list of affected entities and persons who stand to incur direct impacts and/or costs, but also potentially significant benefits, from this rulemaking:

- Arizona Department of Environmental Quality (ADEQ);
- Arizona Water Provider Agencies (WPAs);
- Municipal governments;
- WPA water customers, both residential and nonresidential;
- General public; and
- Arizona environment.

D. Cost/Benefit Analysis:

Comprehensive assessment of the AWP program requires identification of the program's impacts across affected persons and entities. Future AWP implementation can be expected to result in a range of impacts, both beneficial and adverse, which could include:

- Improvements in water availability throughout the water system;
- Operational changes for WPAs;
- Increased capital and operating and maintenance (O&M) expenses for WPAs;
- Increased rates for water customers;

- Enhanced drought resilience of the water system;
- Potential shifts in water rights allocations; and
- Changes in agricultural water usage.

The nature and magnitude of AWP-related costs and benefits will depend on several key factors related to each entity's AWP technology choice and the approach necessary for its implementation, as well as the context within which future development occurs. As noted previously, the voluntary nature of the AWP program allows entities to choose freely whether to engage with the program and thus evaluate potential cost impacts well in advance of adoption.

This EIS is a program-level assessment that evaluates the general impacts from future AWP implementation through the AWP program. As such, it does not estimate specific impacts for any individual project, as those would inherently require consideration of that project's specific circumstances (e.g. water demand, location, and hydrology) and resource conditions. This EIS acknowledges that each AWP project will have cost increase impacts on both a participating WPA and its customers, while advising that project-level assessments and precise quantifications of any specific impacts (e.g., water rate increases to customers, additional permitting fees to ADEQ, potential changes in water usage patterns, changes in infrastructure maintenance costs, possible need for additional staff or training, and potential changes in local ecosystems due to altered water flows) were not evaluated as part of this EIS. Nonetheless, this EIS provides a general assessment of the expected cost effects on WPAs and ADEQ from the AWP program. This section outlines ADEQ's analyses of the expected costs and benefits of this rulemaking, made through consultation with ADEQ staff and AWP subject matter experts (SMEs). Part 1 provides a summary table of the affected stakeholder groups with a description of identified potential AWP program effects, and their corresponding revenue and cost effect findings. Part 2 provides a more detailed discussion of stakeholder impacts, analyses, and findings.

1. Part I - Cost/Benefit Stakeholder Matrix:

Minimal	Moderate	Substantial	Significant
\$10,000 or less	\$10,001 to \$1,000,000	\$1,000,001 or more	Cost/Burden cannot be calculated, but the Department expects it to be significant.

Description of Affected Groups	Description of Effect	Increased Cost/Decreased Revenue	Decreased Cost/Increased Revenue
A. State and Local Government Agencies			
Arizona Department of Environmental Quality (ADEQ)	Increased agency responsibilities for administration, oversight, and management of AWP "fee-for-service" program, in which the State will be reimbursed for most AWP-related costs.	Minimal	
	Initial start-up, implementation, and subsequent program oversight activities may result in non-reimbursed costs to the State.	Moderate	
Water Provider Agencies (WPAs)	Increased compliance and monitoring	Moderate	
	Construction of AWTF and O&M responsibilities.	Substantial	

	Revenue changes from expanded customer base and/or deliveries.		Significant
Municipal Governments (non-WPAs)	Coordination with WPA and other agencies.	Moderate	
	Impact on tax revenue from resulting community expansion.		Significant
B. Customers			
WPA Customers	Impact to user water rates.	Minimal	
	Additional water supply that will allow existing and new business and residential growth.		Moderate
	Impacts upon public health related to water quality.	None identified	None identified
C. General Public			
Arizona Water System	Overall net increase in water availability. Additional water will allow community economic development and growth.		Minimal
	Existing surface water purchases can be diverted to other users or uses.		Moderate
	Groundwater resources can be made available for other users or uses.		Significant
	Diverted wastewater outflow may decrease return flows for downstream users.	Minimal	
Downstream Users	All existing supply commitments will be maintained or renegotiated, however diversion of wastewater outflows for AWP use may impact some downstream users. State environmental and permitting processes will consider and address project-specific cases and conditions. Negative impacts to downstream users are thus expected to be minimal (subject to mitigation if necessary).	Minimal	
D. Arizona Environment/ Ecosystem			
Environmental	Reduced groundwater use and depletion with decreased risks of land subsidence and infrastructure damage.		Significant
	Reduced water outflow from wastewater treatment facilities may result in reduced groundwater recharge.		Minimal
	Reduction in poor quality outflow from wastewater treatment facilities may improve water quality in receiving water body		Minimal

2. Part II - Individual Stakeholder Summaries / Calculations

The following section provides an explanatory discussion of expected AWP costs and benefits to the program's various stakeholders. The section outlines the key factors and analysis used to determine the impact findings reported in Part 1 of Section D, above.

State and Local Government Agencies - ADEQ

ADEQ will incur moderate costs as a result of implementing this rulemaking and administering the program. The rulemaking process itself required significant staff time for technical review, rule composition, facilitation and evaluation of public input and other necessary tasks. Additionally, ADEQ will incur costs for AWP-related staff expansion and performance of new AWP-associated administrative responsibilities needed to implement and operate the AWP program. ADEQ currently anticipates that it will need to hire new staff with the necessary technical expertise for a variety of program implementation and oversight roles.

These positions will likely include engineers (for design review and compliance of AWP facilities) and non-engineer staff for

administrative tasks (e.g., project management, permit writing, operator certification coordination, other program support needs, etc.).

The AWP program's duties and tasks will vary based on the number, type, and phase of WPA participants and it is expected that adequately qualified agency staff may be able to perform several roles. It is expected that the AWP program will grow over time as more utilities seek and implement AWP permits, with permitting and administrative support growing equivalently. Nevertheless, in order to support the administration of the AWP program in the near term, ADEQ plans on hiring 2.5 new full-time employees (FTE). These 2.5 FTEs will be split primarily between permit specialist positions, inspectors, and administrative duties. Funding those positions will incur moderate costs to ADEQ annually which will be offset by permit service fees and annual fees.

There will also be costs associated with meeting requirements during the AWP approval and permitting process, which will adhere to all applicable state laws and aim to serve the regulated community while being protective of public health and the environment. ADEQ envisions that this permitting process will function similarly to other ADEQ permitting processes (such as for obtaining Aquifer Protection Permits). The AWP permitting process was developed and will be adopted into the A.A.C. in accordance with rulemaking requirements in the Arizona Administrative Procedure Act.

ADEQ's management and administration of the AWP approval and permitting process will be performed on a "fee-for-service" basis, under which the State will be reimbursed for most AWP-related costs, and thus future ADEQ responsibilities for the AWP program should be achieved with little fiscal cost to the State of Arizona. Instead, as described below, administrative and oversight costs for AWP deployment will be borne initially by WPAs and then ultimately passed on to customers for cost recovery through rate-setting.

Water Provider Agencies (WPAs)

The decision to participate in the AWP program rests entirely with any WPA wishing to pursue AWP as an addition to their drinking water portfolio. For those WPAs choosing to implement AWP, there will be increases in costs, primarily associated with permitting/compliance/regulation, capital investment, and operations. Participating WPAs will incur program-specific regulatory and compliance costs, capital costs for AWTF construction and system integration with their water systems, and additional operations and maintenance (O&M) costs over the long-term. Other additional program-specific regulatory and compliance costs could include permitting, compliance costs to meet new environmental standards, and expenses for regular inspections and audits. As noted previously, WPA-incurred costs will be largely recouped from customers through adjustments in water rates (subject to Arizona Corporation Commission approvals).

Data collected for this EIS aims to provide a representation of the economic impacts expected from implementing AWP technologies in Arizona and includes information from stakeholders working on various aspects of AWP rulemaking. Analysis for this EIS involved the review of key SME opinions solicited by ADEQ to support its development of high-level estimates for projected permitting, compliance, capital, and O&M costs to participating WPAs.

AWP-related costs have been assessed, estimated, and reported "in toto" in many cases, as appropriate. This approach best meets

this EIS's purposes of representing and evaluating the overall net economic effects of the final rulemaking by determining the overall total combined costs for the various component cost items. This approach is particularly appropriate for evaluation of O&M and compliance costs, which may be performed by an individual staff person; are likely project-specific; and/or are inter-related or inter-dependent, preventing them from being reliably estimated individually and simply aggregated. Furthermore, a higher-level summary assessment may provide a more appropriate and reasonable valuation given inherent imprecision estimating costs that are project-specific, numerous, relatively small, and difficult to quantify individually.

While there will be cost increases, the potential exists for AWP technology to cost less than other available alternatives. As a result, participating WPAs may realize a benefit (cost savings) from AWP implementation.

Water Provider Agencies (WPAs) - Implementation Costs

Implementation costs for an AWTF could include: land acquisition, site preparation, purchase, and installation of advanced treatment technologies, system integration with existing water systems, and engineering and permitting. System integration could involve infrastructure upgrades, installation of new pipelines, and development of blending facilities. The AWP program includes considerable flexibility for each participating WPA to select the AWP technology and approach most suitable and cost-effective for its specific circumstances.

In general, the technical requirements of AWP deployment will result in facility designs that will require capital costs related to the development and building of all new required AWP infrastructure. The potential costs of implementing technological enhancements related to AWP processes within existing wastewater infrastructure are discussed below. Key WPA technical requirements for AWP development are also summarized, with additional discussion on this EIS's evaluation approach to, and findings on, expected impacts to participating WPAs. While the detailed technical and design requirements incumbent upon the WPA applicant are detailed in the final rule, the following technical and design capital costs for AWP development and installation will predominantly impact the WPAs.

WPA Implementation Costs - Permitting

The permitting process complies with all relevant state laws, with the dual aim of serving the needs of the regulated community and safeguarding public health and the environment. The fees established in this rulemaking are in direct response to a legislative mandate to ensure that the rule establishes "permit fees sufficient to administer a direct potable reuse of treated wastewater program" with all fees deposited in the water quality fee fund (A.R.S. § 49-211(A)). This structure mimics the fee approach for other Water Quality Division programs, which are self-funded, fee-based programs. Therefore, the objective in setting AWP fees for permittees - the Water Provider Agencies (WPAs) (or Advanced Water Purification Responsible Agencies, i.e. "AWPRAs") - is to fund the program from the regulated entities, who voluntarily undertake participation in the AWP program. While ADEQ is guided by its statutory mandate, ADEQ did analyze other direct potable reuse (DPR) programs within other states. However, upon analysis, ADEQ determined that a comparison of these states provides minimal value to comparing the reasonableness or adequacy of AWP's fees.

Other states with DPR regulatory programs in development that ADEQ analyzed include Texas and Colorado. According to reports between ADEQ and the Colorado Department of Public Health and the Environment (CDPHE), Colorado's DPR regulations are established, but neither the staff, nor the fees to support the program have been fully determined or installed. Despite the installation of the regulations, CDPHE is not yet administering the program because there are no current permittees. Currently, CDPHE is actively working with stakeholders to determine the best way to derive funding for the program. According to reports between ADEQ and Texas (through the Texas Commission on Environmental Quality (TCEQ)), Texas' DPR regulatory program is funded through a combination of federal and state funds and fees. Therefore, TCEQ is not required to recover its full DPR program cost through DPR program fees alone. In fact, according to reports between ADEQ and TCEQ, Texas' DPR program does not currently have DPR-specific fees.

Considering the comparative analysis above and ADEQ's legislatively required financial structure in A.R.S. § 49-211(A), ADEQ believes the fees contained in the final rule (*see* A.A.C. Title 18, Chapter 14, Article 1) are in line with the Legislative mandate and carefully designed to support the administration of the program (*see* Heading No. 7, subheading "Fees" above).

WPA Implementation Costs - Enhanced Source Control

Traditional source control programs are designed to protect wastewater treatment plant infrastructure, collection systems, and receiving water bodies under an existing regulatory framework through the National Pretreatment Program (NPP) of the federal Clean Water Act. Because AWP projects create potable water, directly, without an environmental buffer, the program requires Enhanced Source Control (ESC).

ESC includes the control, elimination, or minimization of "constituents of concern" discharged from non-domestic dischargers into a wastewater collection system. Such constituents of concern include federally-regulated chemicals, AWP-regulated chemicals, and performance-based indicator compounds, which are necessary to eliminate or minimize discharges of constituents of concern into the wastewater collection system that is providing the source water for the Advanced Water Treatment Facility (AWTF) in the AWP project.

ESC measures may result in capital and/or increased O&M costs for wastewater customers in which constituents of concern have been found. The magnitude of the cost increases will vary, but in many cases it is anticipated that simple technology discharge management measures (such as temporary retention tanks and scheduled releases, sand filtration, coagulation/flocculation, or use of activated charcoal) could be effective and relatively low cost.

Additionally, a Pollutant Reduction and Elimination Plan specific to each ESC implementation will need to be developed to build relationships with non-domestic dischargers, increase participation in pollution prevention methods to control release of constituents of concern in the collection system, and educate the public about protecting source water. Additional information regarding the specifics of individual ESC programs can be found in R18-9-E824.

WPA Implementation Costs - Nitrogen Removal

The AWP program recognizes the critical importance of nitrogen removal during the treatment process. Nitrogen, primarily in the

forms of nitrate and ammonia, can have significant environmental and health impacts if not adequately managed. The AWP program implements flexible strategies for nitrogen removal, allowing facilities to utilize either wastewater treatment processes at water treatment facilities or advanced treatment technologies at AWTFS. These include: biological nitrogen removal (BNR), which uses bacteria to convert nitrogen from one form to another; membrane bioreactors (MBRs) that combine conventional treatment with membrane filtration; an anaerobic ammonia oxidation process that converts ammonium and nitrite directly into nitrogen gas; ion exchange, which removes nitrogen compounds by exchanging them with other ions; and/or adsorption, where nitrogen-containing compounds adhere to the surface of a solid phase.

The choice of strategy depends on various factors, such as the concentration and form of nitrogen in the wastewater, discharge requirements, available infrastructure and resources, and overall treatment objectives. This dual-pathway approach ensures that the specific needs and capacities of different facilities can be met while still achieving the stringent standards required under AWP.

WPA Implementation Costs - Advanced Oxidation Process

The Advanced Oxidation Process (AOP) is a cornerstone of the AWP program's treatment strategy under the minimum design criteria of the rule, R18-9-F832. AOPs are designed to generate highly reactive hydroxyl radicals, which effectively oxidize and break down a wide range of organic contaminants. This AWP program mandates the inclusion of an AOP treatment process in all AWTFS treatment trains, with specific performance benchmarks, achieved through a selection of one of two available methods. This requirement underscores the program's commitment to addressing contaminants of emerging concern and ensuring the safety and quality of the treated water, and the dual-pathway approach ensures that the specific needs and capacities of different facilities can be met while still achieving the stringent standards required under AWP.

WPA Implementation Costs - Other Technical and Design Requirements

In addition to nitrogen removal and advanced oxidation, the AWP program outlines a comprehensive set of technical and design requirements. These include the establishment of multiple barrier treatments, management of total organic carbon (TOC), and the implementation of robust monitoring and reporting systems. The program also emphasizes the need for full-scale verification testing, corrosion control measures, and cross-connection prevention to maintain the integrity of the water supply.

WPA - Operational, Monitoring, and Compliance (OMC) Costs

Once an AWTFS has been built, there will be subsequent operating processes and protocols that will increase annual O&M expenditures for a WPA. Additional O&M costs over the long-term could encompass routine system maintenance, replacement of aging equipment, energy costs, personnel costs for system operation, and monitoring, and expenses for ongoing water quality testing and reporting. It is not anticipated that AWP adoption will have any impact upon non-participating WPAs.

Operating an AWTFS involves a variety of costs. These include the cost of energy required to run the facility, the cost of chemicals used in water treatment processes, and the cost of labor for personnel who operate and maintain the facility. Additionally, there are costs associated with the regular maintenance of equipment and infrastructure, as well as the eventual replacement of aging equipment. These costs can vary depending on the size and complexity of the facility, the quality of the source water, and the

specific treatment processes used.

WPA - OMC - Annual Labor, Power, Chemicals, Replacement and Maintenance

The annual costs of operating an AWTF include labor, which refers to salaries and benefits for employees who operate and maintain the facility. Labor may include costs for training and professional development. Annual costs also include power, the cost of the electricity needed to run the facility's pumps, treatment processes, and other equipment. In addition, many water treatment processes require the use of chemicals to remove contaminants from the water. The cost of these chemicals can vary depending on the quality of the source water and the specific treatment processes used. Finally, over time, equipment and infrastructure will need to be repaired or replaced. These costs can be significant, especially for larger facilities or those using more advanced treatment processes. Regular maintenance can help to extend the life of equipment and reduce the need for costly replacements. These costs are ongoing and must be budgeted for each year to ensure the smooth operation of an AWTF.

WPA - OMC - Operator Certification

An additional certification will be required for operators of certain AWPRA facilities, including all AWTFs and some water reclamation facilities. Such additional certification will naturally come with training and implementation costs, but will also provide the benefit of improved understanding of AWP technology and operations at the WPA level. Operator certification standards for AWP systems will be required to encompass the specific knowledge, skills and experience to maintain the reliability, resilience, and continual performance of AWP systems and respond adeptly to any system failure. The new certification process will encompass a range of critical elements, including comprehensive coverage of AWP technologies, a deep exploration of source water risks and risk management strategies, proficiency in critical control point methodologies, in-depth knowledge of specific AWP regulatory requirements, and the capability to manage operational responses effectively.

The certification program for AWP operators is similar to that of the existing water and wastewater certifications from the American Water Works Association (AWWA) - California - Nevada Section. This Advanced Water Purification Operator Certification would also focus on specific advanced treatment technologies required for AWP and include general requirements to define AWP in the broader picture of public health protection, pathogen and pollutant targets, and other issues. WPAs will need to ensure that its operations staff have the necessary knowledge and experience to successfully complete certification.

WPA - OMC - Enhanced Source Control

As described above, ESC involves strategies to prevent or reduce pollutants in the water supply at the source. The costs associated with ESC processes can include monitoring costs for regular testing of water quality, infrastructure costs for construction or upgrade of facilities to prevent contamination, and regulatory compliance costs for adhering to environmental regulations. Additionally, there are costs for education and outreach to inform the public or specific industries about best practices for preventing water pollution, and maintenance costs for upkeep of infrastructure or equipment used for source control.

While these costs can be significant, the benefits of ESC, such as improved water quality, reduced treatment costs, and better public health outcomes, often outweigh the expenses. Costs can vary depending on local conditions, the specific water source, and the

nature of potential pollutants. Therefore, a detailed cost/benefit analysis by an AWPRAs is often necessary when considering ESC measures.

WPA - OMC - Chemical Monitoring

ADEQ has established a three-tiered monitoring approach to managing regulated chemicals in the treated wastewater at the water treatment facility under the AWP program. Tier 1 includes monitoring of chemicals currently covered under the Safe Drinking Water Act (SDWA); Tier 2 includes AWP-specific contaminants that are not federally regulated but may pose a health concern; and Tier 3 requires performance-based indicators to establish treatment performance. At each tier, robust monitoring is required, resulting in increased O&M costs, which ensures high standards of water quality are maintained for WPA customers and any downstream users/uses.

WPA - OMC - Monitoring and Reporting

Participating in the AWP program will come with increased monitoring and reporting requirements, and associated costs. Beyond costs, however, there will also be considerable benefits from increased monitoring and reporting. First, increased collection of data and technical information will make WPA staff better informed about, and better able to track and measure, the operations and performance of their facilities. Additional collection of water recycling metrics, for instance, can improve operator and manager understandings of their current performance and assist them with adapting and improving, so that they can achieve higher standards and/or greater efficiencies.

Second, improved tracking of performance data and metrics will facilitate comparisons between different AWP systems, enhancing ADEQ's and each WPA's ability to learn and improve future operations. Data reporting to ADEQ by individual WPAs, for instance, will inform and support ADEQ's monitoring and oversight capabilities.

WPA - OMC - Federal and State Compliance

The AWP rulemaking requires participating WPAs to conform with existing EPA guidelines. There are specific EPA compliance requirements in addition to the required chemical monitoring presented above. These include:

- 1. Laboratory Analysis. Laboratories performing analyses must comply with the Health and Safety Code, known as the Environmental Laboratory Accreditation Act. Chemical analysis methods should be approved by the EPA for use in compliance with the SDWA.
- 2. Reporting. AWTFs are required to report analytical results for ongoing compliance monitoring of pathogens and chemicals. Reports must include detail regarding the ESC program, cross-connection incidents, and any other relevant information as per AWP program requirements.

These requirements are part of final program standards that will ensure the protection of public health through the control of both pathogens and chemicals in the AWP process.

WPA - OMC - Additional Agency Compliance

The final regulations for the AWP program require WPAs to adhere to established numerical criteria (such as regulated pollutant

concentrations that must not be exceeded to protect water quality and public health, and action level thresholds that necessitate immediate corrective measures). These standards and thresholds, which may include limits on contaminants like nutrients or heavy metals, are set by associated agencies or organizations and are integral to WPA operation.

WPA - OMC - Public Communications

As part of AWP implementation, each WPA and associated partners must develop and implement a “Public Communication Plan” within their service area to notify the public of the possibility of their transition to AWP, address public concerns, build public confidence, and garner public acceptance for AWP (see R18-9-B811). Most WPAs already have community relations staff resources allocated for their current water programs, so the level of additional effort required for adequate and successful communication to the public about AWP will vary between agencies according to their circumstances.

WPA - Cost Evaluation

ADEQ has identified three representative AWP projects for analysis within this EIS, each using a different AWTF treatment train: 1) Ozone-Biologically Activated Carbon (BAC), 2) Ozone-BAC with Side-Stream Reverse Osmosis (RO), and 3) Full-Stream RO. These projects have been selected as they represent a range of treatment options, reflecting the different processes available to meet the diverse needs and capacities of different facilities. This EIS evaluated these representative projects to assess expected costs and benefits of implementing AWP technologies using each of them in Arizona, thereby supporting informed decision-making and strategic planning for water resource management in the state.

WPA - Cost Evaluation - Project 1 Ozone-BAC:

This train is adapted from injection well potable reuse (PR) projects. The Ozone-BAC process involves the use of ozone for oxidation and biofiltration for organic and microbial contaminant removal but does not significantly reduce the concentration of Total Dissolved Solids (TDS). This train is ideal for applications where the primary concern is the removal of targeted bulk and trace organic contaminants, but not for cases where the TDS of the source water is high and/or TDS reduction is needed to meet purified water quality targets.

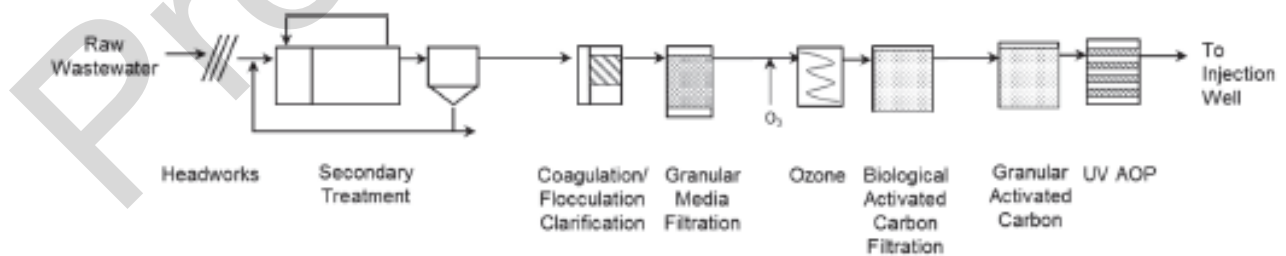

WPA - Cost Evaluation - Project 2 Ozone-BAC with Side-Stream RO:

This train includes a side-stream RO treatment for a portion of the water being treated for enhanced salinity reduction. It is suitable for injection-well PR projects where some salinity must be controlled. The side-stream RO allows for the removal of dissolved

solids from a portion of the water, and thus helps to manage overall salinity levels and to reduce project costs by implementing a more targeted approach to RO treatment.

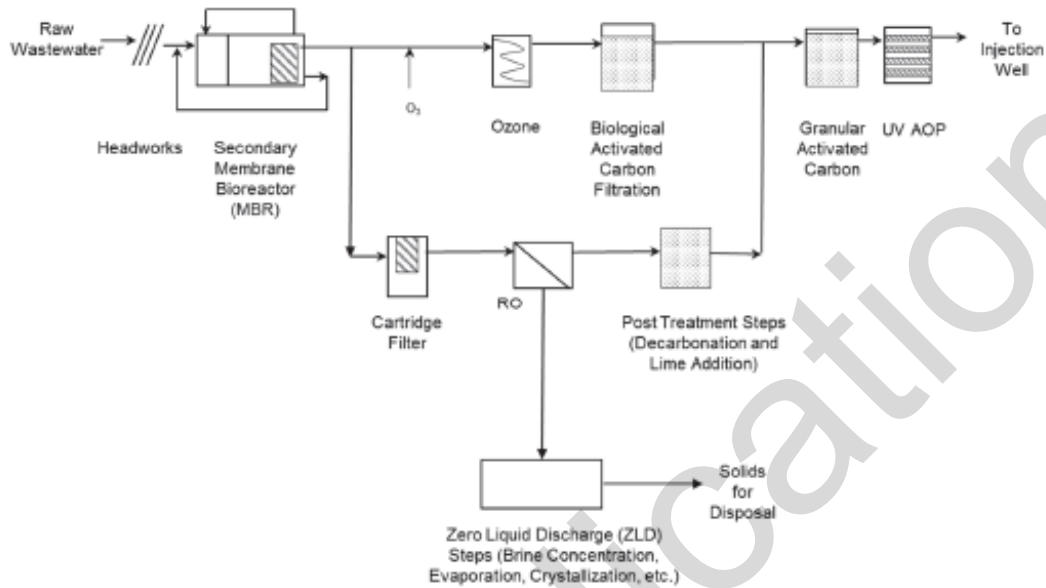

WPA - Cost Evaluation - Project 3 Full-Stream RO:

This train is suitable for injection well PR projects where full-stream reverse osmosis (RO) treatment is required. Full-stream RO treats the entire flow of water, providing comprehensive removal of salts and other dissolved solids. This train is ideal for applications where salinity control is necessary.

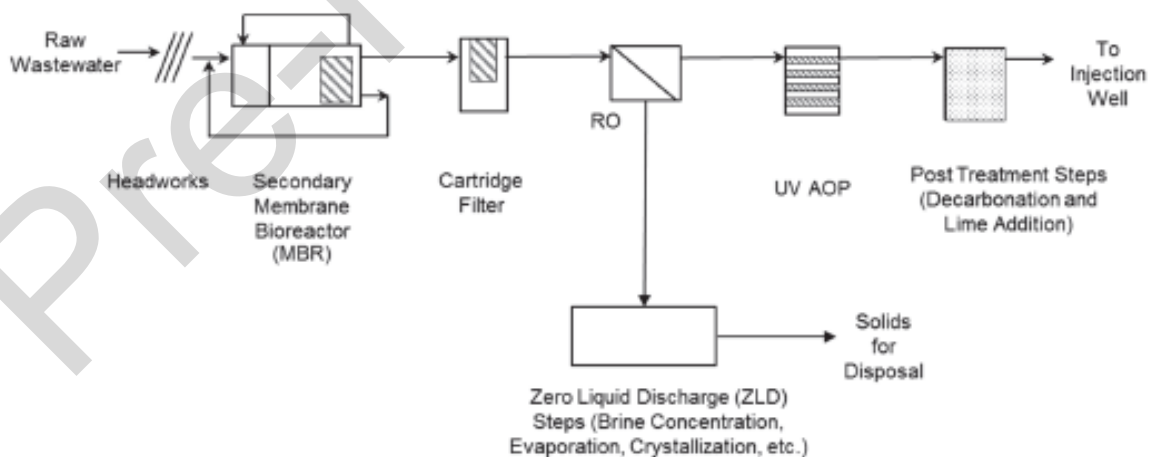

WPA - Cost Evaluation - Capital Cost

Capital and O&M costs have been estimated for each of the three representative AWP projects. These high-level “typical” cost estimates are used to derive approximate unit cost estimates to provide “ball-park” representation of the likely costs for participating

WPA and its customers. Unit-supplied water values are derived from these estimates to provide an indication of the AWP's potential customer costs and enable cost comparisons with other water supply alternatives, such as desalination.

Pre-Publication

The cost data developed for the three representative AWP projects include expenditures for AWTF design and construction, required water recovery facility enhancements, an ESC program, and O&M. Together these demonstrate representative costs that a WPA can be expected to incur to develop and operate a typical 6 million gallon per day (MGD) AWTF with an assumed 30-year useful life. Unit costs are presented in constant 2024 dollars and thus do not include any inflation effects. It is also assumed that an AWTF will be funded with low-interest loans (such as federal Water Infrastructure Finance and Innovation Act programs), which, when applied to current 2024-dollar terms, will approximate to a zero (0) percent real interest rate.

The estimated capital costs for the representative projects are shown in the table below.

Representative Project	Project Type	Capital Costs, \$M	Annualized Capital Costs, \$/AFY
Project 1	Carbon Based Advanced Treatment (CBAT)	\$208.0	\$1,000
Project 2	Carbon Based Advanced Treatment (CBAT) with Sidestream Reverse Osmosis (RO) (a)	\$229.0	\$1,100
Project 3	Full Reverse Osmosis (RO) with Brine Management	\$276.0	\$1,400

Note: (a) Assumes sidestream RO of 55% of CBAT flow. AFY is acre feet per year.

WPA - Cost Evaluation - O&M and Compliance Costs

The estimated annual O&M costs for each of the representative projects are provided in the table below. These costs include labor, materials, equipment repair/replacement and power. Staff costs are based on an estimated average labor cost of \$80,000 and \$0.20 kWh power cost for operations.

Representative Projects	Project Type	Annual O&M Costs, \$M/yr	Annualized Capital + O&M Costs, \$/AFY
Project 1	Carbon Based Advanced Treatment (CBAT)	\$3.3	\$1,520
Project 2	Carbon Based Advanced Treatment (CBAT) w/ Sidestream Reverse Osmosis (RO) (a)	\$8.5	\$2,390
Project 3	Full Reverse Osmosis (RO) w/ Brine Management	\$10.9	\$2,990

Note: (a) Assumes sidestream RO of 55% of CBAT flow. AFY is acre feet per year.

In addition, as discussed above, participating WPAs will incur additional monitoring and compliance costs. These activities are recognized as distinct and additional to the duties required of the AWP's operations staff. However, the net cost to the WPA is expected to be relatively minor, as these responsibilities are standard and often periodic. It is estimated that 1 FTE should be able to perform the necessary monitoring and compliance activities.

Regarding ESC, a high-level summary of the estimated costs for implementing a full ESC Program range from 1.25 to 1.5 FTEs. In some cases, WPAs have reported an additional analytical cost of 2 to 3 FTEs necessary for monitoring events. At a full-burdened typical wage cost of approximately \$139,000 per year, the estimated implementation cost for a full ESC program would be expected to be in the range of \$175,000 to \$210,000 per year.

As discussed previously, ADEQ's oversight and administration of the AWP program will be provided on a fee-for-service basis charged to the participating WPA.

Municipal Governments

The future planning of communities in Arizona will likely be dictated by the availability of water resources, from planning for and permitting additional residential and nonresidential growth; to planning for public facilities, such as schools, offices, and correctional facilities. Therefore, municipal governments are an integral component in the process of selecting AWP or another water source alternative. As a result, municipal governments will likely be working with / directing the WPAs when determining the amount of water needed to support the current needs of and projected growth within their communities. Municipal governments will also be indirectly impacted by the AWP program as it plans for and permits residential and nonresidential development.

It is likely that municipal governments will be directly impacted by the AWP program as they support the WPA in evaluating alternatives for new sources of water. One of the major components specific to any ESC requirements for AWTF operations will be the establishment of legal authority, regulatory agreements between agencies, and specific enhanced wastewater management requirements and compliance. Municipal governments will also likely be responsible for implementing the outreach efforts that will explain the AWP selection process to their communities. In addition, municipal governments as water customers will be impacted by any rate increases that occur from AWP implementation. While there will be impacts to municipal governments from AWP, the impacts are not anticipated to be significantly different from the impacts associated with implementing other water source alternatives. If AWP is more cost-effective than other alternatives, there may even end up being greater demand for residential and nonresidential development in AWP-adopting municipalities because of their more affordable water.

Notably, municipal governments may, in fact, be the WPA in their community. In this scenario, the impacts to the municipal government are best revealed through the WPA impact analysis, above, rather than the impact analysis under this section. If a municipal government is the WPA, their expected impacts are significant.

WPA Customers

AWP is not anticipated to have an impact on water customers served by non-participating WPAs. Only AWP water customers will incur increased costs, as they can expect to face higher water rates once WPAs pass on the costs of AWTF development and operations to them. Customers of participating WPAs will, however, also benefit from the greater availability and reliability of the potable quality water supplied through their community's AWP, as described below, especially if their "willingness to pay and use" value exceeds the price charged to them by the WPA to receive the water. Regardless, all user rate increases are the responsibility of each WPA and as such will vary based on specific circumstances. It is, of course, expected that each participating WPA will do

a comprehensive analysis before AWP adoption to ensure that there is adequate customer demand, support, and ability to pay for any new AWTF within their service area.

As discussed, participating in the AWP program is voluntary and it is anticipated that WPAs will select the water supply alternative that is the most cost-effective and best meets the needs of its customers. Therefore, if AWP is selected, the rate impacts will likely be less than the impacts of alternative water supplies, thus customers may experience less of a rate impact than if AWP was not available.

WPA Customers - Water Supply Availability

WPA customers will benefit from greater water supply reliability and availability from the additional potable water supplied through AWP and will enjoy confidence in their WPA's ability to fully meet its service community's current water needs and future demands. Full representation of an AWP's total impact on local water availability should recognize the following water supply improvements:

- Net increase in supplied water: Unlike water purchases and transfers, wastewater recycling will result in "net new" quantities of potable water, as formerly non-potable water discharges are instead treated for municipal and industrial (M&I) consumptive use.
- Increased Supply Reliability: AWP will provide a more sustainable supply option, since its production will not be directly impacted by meteorological and/or hydrological conditions.
- Local Control and Supply Flexibility: AWP-served communities will reduce their dependency on imported water and/or existing (often dwindling) groundwater resources. The new water supplies obtained from AWP development should allow many communities to maintain or improve their groundwater levels and availability.

As noted previously, only the above qualitative considerations of impacts for customers of AWP-participant WPAs have been provided, as rate impact estimations will be highly project-specific and were not evaluated as part of this EIS.

WPA Customers - Water Quality

As one of ADEQ's three (3) environmental divisions, the Water Quality Division (WQD) is responsible for administering the Department's water protection and improvement programs. The WQD protects and enhances public health and the environment by ensuring that healthy drinking water is provided by public water systems, and by controlling current and future sources of surface and groundwater pollution. The Division's programs include, among others, the Safe Drinking Water program, the Groundwater Protection program, and the Recycled Water program.

All recycled water delivered by AWP systems is anticipated to be of equal water quality to existing drinking water supplies due to advancements in AWP technology and the high water quality standards of the SDWA. As a result, future AWP customers are not expected to face any increased public health risks or concerns from AWP, and indeed can expect to enjoy clean water of high

quality.

General Public

In addition to the direct impacts to WPAs and their customers, AWP deployment can be expected to have broader impacts on the general public. Direct cost impacts from AWP technology adoption are expected to be predominantly experienced by the agencies, businesses, and individuals connected with AWP operations. However, due to the interconnectedness of Arizona's regional and local water systems, and the scarcity and importance of water within the state, future AWP deployment can be expected to have impacts on the broader populations of residents and businesses within the state and state-wide water resources. Key components and constituencies that would potentially be impacted include the Arizona water system, community economies, the environment, and downstream water users, as described below.

General Public - Arizona Water System

The Colorado River system, which supplies 36 percent of Arizona's total water use, has experienced extensive drought conditions for the past 19 years. Furthermore, it can be expected that climate change may result in even greater long-term reductions in Colorado River supplies. Arizona maintains six Active Management Areas (AMAs), designed to sustain the state's economic health by preserving groundwater resources and promoting long-term water supply planning. Established in 1980, these AMAs cover those areas of the state where significant groundwater depletion has historically occurred. As Arizona heads into a drier future, it is unlikely that its groundwater safe-yield requirements will be reliably met and thereafter maintained in any of the state's AMAs. Groundwater currently provides 41 percent of the state's water, but recent groundwater modeling has projected that over the next 100 years, unmet groundwater demand within the Phoenix AMA will reach nearly 4.9 million acre-feet (MAF), and unmet demand within the Pinal AMA will exceed 8 MAF. Furthermore, in 2022, the Federal Government called upon Arizona and its neighboring Colorado River states to conserve between 2 to 4 MAF per year to address the critically low levels in Lake Powell and Lake Mead.

AWP may thus represent an important supplemental water supply source that can enhance the AMA regions and their local sub-areas' abilities to operate more sustainably. The Arizona water system at large could see significant benefits from this rulemaking by providing WPAs with another option for providing potable water. All Arizona water customers, whether they be serviced by an AWP system or other municipal water system, could benefit from improved water availability and reliability within the state's water system if AWP implementation adds substantial net new water supplies to the state's water system.

General Public - Community Economic Development and Growth

The Arizona Department of Water Resources (ADWR) created the Assured Water Supply Program and the Adequate Water Supply Program to address the concern of limited groundwater supplies in Arizona. The Assured Water Supply Program operates within Arizona's six AMAs and is designed to sustain the state's economic health by preserving groundwater resources and promoting long-term water supply planning. Conversely, the Adequate Water Supply Program operates outside of the AMAs to ensure that water supply adequacy or inadequacy is disclosed in the public report provided to potential home or land purchasers, and that any

water supply limitations are described in promotional or advertising material for new developments. Each program has independently verified that current water supply cannot match pace with current projections of population growth and water supply demand.

According to recent data, Arizona witnessed a substantial 12% population increase between 2010 and 2020. Furthermore, more than another one million new people are predicted to take up residence in Arizona over the next decade. At the state's current average water use rate of 146 gallons per day, this projected one million population growth will result in 164 thousand acre-feet of increased residential water demand. New water supplies to meet demand are therefore critically required, and AWP represents an option with considerable potential for supporting the water demands of such anticipated growth and the requirements of the programs. Indeed, in some areas, growth may not be possible without AWP; while in others, AWP may provide the least-costly option for meeting the increased water demand of Arizona's planned development.

Additionally, AWP sourced water also supports future economic development since it can be readily used for a wide variety of purposes and/or locations. In-state surface water supplies, on the other hand, are typically highly location dependent and also subject to water right requirements that may restrict who may use the water where and for what purposes. AWP source water can thus be used to meet Assured Water Supply requirements in sub-basins and areas with insufficient native groundwater to support the future water needs of all proposed development, whether it be residential or commercial. Finally, AWP sourced water may also reduce the demand for future water transfers that reallocate water supplies from agricultural use for urban customers, which will result in land fallowing and lost agricultural activity.

General Public - Downstream Users

WPA applicants to the AWP program will be required to maintain all previous commitments to downstream water users. WPAs will have to demonstrate that they have the necessary water use rights to divert wastewater supplies for their AWP operations. Use terms and conditions for wastewater outflows will vary between locations and specific utilities. In some cases, dependent ecosystems may formally or informally be recognized as committed water users for wastewater outflows; as such, the impacts to adjacent ecosystems may warrant mitigation. This would be evaluated on a project-specific basis during each AWTF's permit approval process.

Except in cases of contracted use commitments (e.g. non-potable deliveries to the Palo Verde nuclear plant), within most of the state's hydrological systems, wastewater discharge return flow effects and downstream uses are typically limited and not well defined. As a result, potential AWP impacts to downstream users will be project-specific. They are also difficult to estimate and likely outside the WPA's jurisdiction and management authority. As a result, such AWP-related effects were not evaluated as part of this EIS.

Arizona Environment

Current state environmental regulations will evaluate project-specific impacts that may be expected from any proposed AWP development and will recommend appropriate mitigation and/or design changes as necessary to minimize any significant adverse

environmental effects. However, in general, the incidental effects from WPAs' discretionary (i.e. uncommitted) current wastewater discharges may be considered to represent indirect and secondary outcomes with lesser relevance/importance than the AWP's direct positive impacts on regional water availability and reliability. AWP recycling of wastewater outflows will not directly affect the state's groundwater resources, since AWP will not result in direct groundwater extraction. AWP may result in some potential indirect groundwater reductions from its diversion of current wastewater outflows. Groundwater conditions within the state could be indirectly impacted, to the extent that current wastewater discharges would normally recharge groundwater aquifers though natural percolation will be diverted by AWP reuse of those water quantities.

AWP may also have a net-positive impact on state groundwater resources by reducing the use of groundwater to meet the state's future water supply needs. It is anticipated that AWP-related groundwater depletion will be less than that which would result from groundwater extraction water supply options designed for either potable use or as new water supply alternatives (e.g. desalination of brackish groundwater). Improved groundwater sustainability can also be expected to result in environmental benefits from reduced land subsidence risks and/or adverse intrusion effects on other aquifers. The economic costs of any such adverse impacts will vary depending on the specific circumstances but will typically represent substantial economic losses to affected properties, and land uses that will be costly to mitigate.

E. A general description of the probable impact on private and public employment in business agencies, and political subdivisions of this state directly affected by the rulemaking:

ADEQ expects that net direct effect on long-term public or private employment from this rulemaking will result in a minimal or negligible increase. While construction of each new AWTF will result in short-term employment increases for the regional economy, AWP implementation is not anticipated to have direct, long-term impact on local employment. As discussed in Section D, each new AWTF will require a limited increase in operational staff for participating WPAs. Similarly, ADEQ staff necessary for future program oversight and administration will require a relatively small increase in agency staffing. Furthermore, the AWP-related job impacts for both WPAs and ADEQ will likely be similar compared to those that would otherwise be expected from other water supply expansion alternatives (e.g. new brackish desalination).

The extent that any AWP-related increase in employment (both from its construction and subsequent operations) will represent net gains for the region's economy will depend on whether the WPA might otherwise be expected to pursue alternate development of their water system (e.g. new desalination facilities) or would forego system expansion entirely. In either case, the direct net effect on private and public employment within the region's economy would be very small and represent a near negligible change for the region's business sectors and economy.

The potential indirect employment impacts from the AWP, however, could be more substantial if WPAs would otherwise be unwilling or unable to improve their water supplies. Under those circumstances, AWP implementation would be expected to allow future economic growth and development that would otherwise not occur under Arizona's Assured and Adequate Water Supply Programs' requirements. In this case, new employment generated by the increased economic growth and development

might be recognized as an “increase to employment” benefit that could, at least in part, be attributed to the AWP.

F. A statement on the probable impact of the rules on small business:

In this EIS, ADEQ uses the term “small business” consistent with A.R.S. § 41-1001(21), which defines a “small business” as “a concern, including its affiliates, which is independently owned and operated; which is not dominant in its field; and which employs fewer than one hundred full-time employees or which had gross annual receipts of less than four million dollars in its last fiscal year.” ADEQ has determined that, for the most part, this rulemaking will not generate a significant and/or disproportionate impact on small businesses. As noted previously, the AWP is a voluntary program that will provide each participating WPA with new opportunities for increasing and improving local water supplies. As such, each WPA can determine whether an AWP program’s benefits to its operations and customers will justify investment costs into the program and potential increases in subsequent annual O&M expenses. AWP costs will most directly affect WPAs, with secondary effects on customers (because of improved water availability and pass-through rate cost impacts). AWP rules are thus anticipated to have only an indirect impact on Arizona small businesses. Furthermore, in the absence of any differentiation in either the distribution of AWP-related water supply changes or rate charges, small business water customers would not be expected to be disproportionately impacted as compared to a WPA’s other customers.

1. An identification of the small business subject to the rules:

As discussed above, no small businesses would be directly subject to AWP rulemaking, as it is a voluntary program for WPAs.

2. The administrative and other costs required for compliance with the rules:

All administrative and other compliance costs related to the AWP will be directly applicable to ADEQ and the participating WPAs. Any such costs incurred by participating WPAs will have only an indirect cost effect on its customers (residential, business, municipal, and other nonresidential) as approved by the Utilities Division of Arizona’s Corporation Commission. Furthermore, in the absence of any differentiation in either the distribution of AWP-related water supply changes or rate charges, small business water customers are not expected to be disproportionately impacted compared to a water utility’s other customers.

3. A description of the methods that the agency may use to reduce the impact on small businesses, as required in

A.R.S. § 41-1035:

In the absence of any direct or disproportionate indirect impacts to small businesses from the AWP, no mitigation measures are necessary to reduce any AWP-related future impacts to small businesses.

4. The probable costs and benefits to private persons and consumers who are directly affected by the rules:

See Section D for discussion on ratepayer impacts to AWP customers. Note that probable cost effects from future AWP development and implementation will be limited solely to the WPA customers. Accordingly, no cost impacts from future AWP development and implementation to non-participating WPAs would be expected.

G. A statement of the probable effect on state revenues:

AWP implementation will result in increased oversight and administration by ADEQ, as previously discussed. However, the

AWP program will operate under the State's fee-for-service model, so that ADEQ-incurred administrative expenses will be recovered from AWP applicant application and permit fees. As a result, no decrease in state revenues should result directly from the AWP program. The AWP program can be expected to result in future increases in state revenues to the extent that its supplemental increases in water delivery and supply improvements should foster economic growth and development that would otherwise not occur. The tax and other economic benefits from the AWP supported growth would represent future indirect and predominantly positive effects on state revenues and economic conditions.

H. A description of any less intrusive or less costly methods of achieving the purpose of the rulemaking:

A.R.S. § 41-1055 requires identification and description of any less intrusive or less costly alternative methods of achieving the AWP regulation's purpose. For any such AWP alternatives, the required description needs to provide: (1) the monetizing of its costs and benefits and (2) the rationale for not using non-selected alternatives. As discussed previously, AWP participation is entirely voluntary and in no way precludes any WPA from instead implementing another approach or water supply resource to meet its water supply needs. This approach thus recognizes that each WPA is the best and most appropriate analyst of, and decision-maker, for its own specific water system needs, resources and alternative supply options.

As such, potential AWP program participants will evaluate their own agency/project-specific circumstances to determine if there are, in fact, less intrusive or less costly alternative methods that would be preferable. Furthermore, the AWP rulemaking's programmatic nature generally precludes any specific project-level determinations of its relative cost or intrusiveness, since any such determination will depend on specific project circumstances as well as implementation approach and design. The cost-effectiveness determination and rationale for any AWTF's development will be the sole responsibility of its WPA and will consequently override and/or negate the applicability of this EIS' alternative methods description requirements.

Generally, brackish groundwater reverse osmosis (BWRO) is considered the primary alternative for obtaining net new water supplies that would match AWP in terms of supply reliability and local control. However, BWRO is likely to be a more expensive alternative, and still comes with its own set of limitations and project-specific circumstances. There is an extensive body of research and analysis on the technical and economic viability of both recycled water and BWRO development. Review of these studies indicates that there is a wide range in the costs of supplied water for these systems, determined by a variety of factors. Several key factors will determine the technical and economic viability of BRWO deployment: (1) groundwater resource conditions, including both supply quantities and salinity levels; (2) pumping depths for extraction; (3) locational proximity to community water systems and conveyance/integration infrastructure requirements; (4) energy consumption; (5) brine by-product waste disposal (either ground injection or treatment for landfill); (6) capital and operational costs; and (7) environmental concerns and impacts from long-term groundwater depletion, subsidence potential and/or effects on neighboring aquifers.

It is also important to note that all else being equal, AWP systems facing salinity issues that require reverse osmosis treatment are likely to have higher supplied water costs, and these may be comparable to those that would be expected for BWRO supplied

water.

I. A description of any data on which the rule is based with a detailed explanation of how the data was obtained and why the data is acceptable data:

The purpose of this section of the EIS is to identify the data and analysis previously used to develop the AWP program. As explained throughout this EIS, the AWP program will offer Arizona WPAs new opportunities to develop potable water sources through treatment and recycling of its wastewater outflows. Due to the need for additional water supply options, the Arizona legislature mandated pursuit of the AWP program through A.R.S. § 49-211. As discussed in Section D, the AWP program is entirely voluntary, and its regulations will apply solely to participating WPAs. As a result, non-participating WPAs will not be affected by any AWP requirements. ADEQ has chosen to offer AWP as a voluntary and optional program to place decision-making responsibility for needs determination, cost evaluation and participation on the WPAs who will be responsible for implementing the technology and who best understand how it stands to impact their specific circumstances, and customers' needs. ADEQ has undergone an extensive and detailed process to develop its AWP regulations. The AWP regulation development has to-date included significant planning and analysis for its formulation. In addition to technical analyses, ADEQ has consulted with WPAs that are considering participating in the AWP program.

Please see Section 7 of this NFRM for a comprehensive overview of AWP regulations, as well as the rationales and data used for the AWP program's design and implementation approach. The various AWP regulatory requirements have generally been developed and adopted to ensure that AWP program implementation fulfills the agency's overall mission to protect and enhance public health and the environment of Arizona. Towards this goal, the AWP program has been developed and designed to conform with ADEQ's guiding principles: i. protective of public health and the environment; ii. community-supported; iii. scientifically-based; iv. reasonably affordable; v. transparent, informative, and communicative; vi. specific, practical, flexible, and implementable; and vii. accounts for future conditions and growth.

The protection of public health and the environment, and the development of a program grounded in hydrological science, are the preeminent guiding principles that are most relevant to AWP program requirements and standards. As such, ADEQ has focused extensively and deliberately on AWP regulations that will ensure the water supply system's proposed technical, design, operational, and compliance regulations address public health concerns, and that public safety is maintained. Without ADEQ's rigorous regulatory guidelines and future oversight, there would be an increased risk of potential public health/safety issues and/or incidents. Due to the complexity of the technical issues and the wide variety of WPA circumstances, extensive regulatory guidance, requirements, safeguards and agency oversight are essential to ensuring that AWP can be a safe, sustainable, and effective new source of potable water for Arizona's water users.

11. A description of any changes between the proposed rulemaking, to include supplemental notices, and the final rulemaking:

No changes.

12. An agency’s summary of the public or stakeholder comments made about the rulemaking and the agency response to the comments:

Comment 1: General Public

How many billions of taxpayer money are you going to waste on this project?

ADEQ Response 1:

ADEQ appreciates the comment. AWP is a voluntary program in which water provider agencies may choose to participate in after outreach and collaboration with their customers. Applicants must develop a Public Communications Plan which, among other requirements, ensures the applicant notifies all drinking water consumers of its intention to apply for an AWP permit and maintains communication with consumers throughout all major program phases (*see* R18-9-B811). ADEQ expects water provider agencies to determine whether AWP fits the needs of water customers in their respective service areas and to ensure that there is adequate customer demand, support, and ability to pay for any new Advanced Water Treatment Facility (AWTF).

The AWP program follows a fee-for-service model, deriving funding from applicants and permittees via hourly review rates for permit applications and related components as well as from annual fees. The costs charged through the program are commensurate with projected costs necessary to adequately support the program. The AWP fees are designed and calculated to be fairly assessed, imposing the least burden possible to parties subject to the fees.

13. All agencies shall list other matters prescribed by statute applicable to the specific agency or to any specific rule or class of rules. Additionally, an agency subject to Council review under A.R.S. §§ 41-1052 and 41-1055 shall respond to the following questions:

There are no other matters prescribed by statute applicable specifically to ADEQ or this specific rulemaking.

a. Whether the rule requires a permit, whether a general permit is used and if not, the reasons why a general permit is not used:

Yes, this rulemaking establishes the Advanced Water Purification regulatory program, which includes issuing individual permits, pursuant to A.R.S. § 49-211. While the product (advanced treated water or finished water) of an Advanced Water Purification regulatory program facility is substantially the same, the facilities, activities and practices regulated by the program will be substantially different in nature due to the treated wastewater source, a multitude of viable technological process configurations, a swift pace of technological progress in the field and the custom nature of the regulated parties and their circumstances. Moreover, general permits are not “technically feasible” for the Advanced Water Purification regulatory program under A.R.S. § 41-1037(A)(3), and not used in the program.

b. Whether a federal law is applicable to the subject of the rule, whether the rule is more stringent than federal law and if so, citation to the statutory authority to exceed the requirements of federal law:

While the Safe Drinking Water Act (SDWA) (40 USC § 300f *et seq.*) does regulate the treatment and delivery of drinking water from public water systems across the United States, it does not explicitly regulate the treatment of “treated

wastewater” (see R18-9-A801) as a source, which is the subject of this final rule. In fact, SDWA only contemplates surface and ground water as sources for public water systems. Some Advanced Water Purification facilities will be considered public water systems for the purposes of the SDWA and regulated in accordance with the SDWA in addition to the final AWP program.

c. Whether a person submitted an analysis to the agency that compares the rule’s impact of the competitiveness of business in this state to the impact on business in other states:

Not Applicable.

14. A list of any incorporated by reference material as specified in A.R.S. § 41-1028 and its location in the rules:

Not Applicable.

15. Whether the rule was previously made, amended or repealed as an emergency rule. If so, cite the notice published in the Register as specified in R1-1-409(A). Also, the agency shall state where the text was changed between the emergency and the final rulemaking packages:

Not Applicable.

16. The full text of the rule follows:

Rule text begins on the next page.

TITLE 18. ENVIRONMENTAL QUALITY
CHAPTER 14. DEPARTMENT OF ENVIRONMENTAL QUALITY - PERMIT AND COMPLIANCE FEES
ARTICLE 1. WATER QUALITY PROTECTION FEES

Section

- R18-14-101. Definitions
- R18-14-102. Hourly Rate and Maximum Fees for Water Quality Protection Services
- R18-14-104. Annual Fees for Water Quality Protection Services Subject to Hourly Rate Fee

ARTICLE 1. WATER QUALITY PROTECTION FEES

R18-14-101. Definitions

1. "APP" No Change
2. "AWP" means Advanced Water Purification.
23. "Complex modification" means:
 - a. A revision of an individual Aquifer Protection Permit for a facility within a mining sector as defined in A.R.S. § 49-241.02(F)(1); and
 - b. A revision of an individual Aquifer Protection Permit for a facility within a non-mining sector due to any of the following:
 - i. An expansion of an existing pollutant management area requiring a new or relocated point of compliance;
 - ii. A new subsurface disposal including injection or recharge, or new wetlands construction;
 - iii. Submission of data indicating contamination, or identification of a discharging facility or pollutants not included in previous applications that requires reevaluation of BADCT; or
 - iv. Closure of a facility that cannot meet the clean closure requirements of A.R.S. § 49-252 and requires post-closure care, monitoring, or remediation.
34. "Courtesy review" means a design review service that the Department performs within 30 days from the date of receiving the submittals, of the 60 percent completion specifications, design report, and construction drawings for a sewage collection system.
45. "Priority review" means a design review service for an APP Type 4 permit application that the Department completes using not more than 50 percent of the total review time-frame for the applicable Type 4 permit application as specified in 18 A.A.C. 1, Table 10.
56. "Request" means a written application, notice, letter, or memorandum submitted by an applicant to the Department for water quality protection services. The Department considers a request made on the date it is received by the Department.

67. "Review hours" means the hours or portions of hours that the Department's staff spends on a request for a water quality protection service. Review hours include the time spent by the project manager and technical review team members, and if requested by the applicant, the supervisor or unit manager.
78. "Review-related costs" means any of the following costs applicable to a specific request for water quality protection service:
- a. Presiding officer services for public hearings on a permitting decision,
 - b. Court reporter services for public hearings on a permitting decision,
 - c. Facility rentals for public hearings on a permitting decision,
 - d. Charges for laboratory analyses performed during the review, and
 - e. Other reasonable and necessary review-related expenses documented in writing.
89. "Standard modification" means an amendment to an individual Aquifer Protection Permit that is not a complex modification.
910. "UIC" means Arizona's Underground Injection Control Program.
4011. "Water quality protection service" means:
- a. Reviewing a request for an APP determination of applicability;
 - b. Pre-application consultation, issuing, renewing, amending, modifying, transferring, or denying an aquifer protection permit, an AWP permit, an AWP demonstration permit, an AZPDES permit, a UIC permit, a UIC application for an aquifer exemption or an injection depth waiver or a reclaimed water permit;
 - c. Reviewing supplemental information required by a permit condition, including annual reports and closure for an APP;
 - d. Performing an APP clean closure plan review;
 - e. Issuing or denying a Certificate of Approval for Sanitary Facilities for a Subdivision;
 - f. Registering or transferring registration of a dry well;
 - g. Conducting a site visit;
 - h. Reviewing proprietary and other reviewed products under A.A.C. R18-9-A309(E);
 - i. Reviewing, processing, and managing documentation related to an AZPDES general permit, including a notice of intent, notice of termination, certificate of no exposure, and waiver;
 - j. Registering and reporting land application of biosolids; or
 - k. Pretreatment program review, inspection, or audit.
 - l. Reviewing and commenting on AWP permit and demonstration permit materials, including but not limited to, materials submitted to the Department pursuant to A.A.C. R18-9-C814, A.A.C. R18-9-C815, and A.A.C. R18-9-F835.

R18-14-102. Hourly Rate and Maximum Fees for Water Quality Protection Services

- A. The Department shall assess and collect an hourly rate fee for a water quality protection service, except for APP minor permit amendments specified under A.A.C. R18-9-A211(C)(1), (2) and (3) and A.A.C. R18-9-B906(B), unless a flat fee is otherwise designated in this Article, and UIC minor modifications specified under A.A.C. R18-9-C633(A).
- B. Hourly rate fees. The Department shall calculate the fee using an hourly rate of \$174, adjusted annually under subsection (D), except for the UIC program, where the Department shall calculate the fee using an hourly rate of \$145, and the AWP program, where the Department shall calculate the fee using an hourly rate of \$223, both adjusted annually under subsection (D). These rates shall then be multiplied by the number of review hours to provide a water quality protection service, plus any applicable review-related costs, up to the maximum fee specified in subsection (C), adjusted annually under subsection (D).
- C. Maximum fees for a water quality protection service assessed at an hourly rate in Table 1, adjusted annually under subsection (D).
- D. The Director shall adjust the hourly rate and maximum fees listed in subsections (B) and (C) every August 1 to the nearest \$10, beginning August 4, 2023, by multiplying the hourly rate or maximum fee by the Consumer Price Index (CPI) for the most recent year, and then dividing by the CPI for the year 2023. The CPI for any year is the average of the Consumer Price Index for All Urban Consumers, Phoenix-Mesa-Scottsdale, AZ, all items published by the United States Department of Labor, as of the close of the 12-month period ending on June 30 of that year.

Table 1. Maximum Fees

Program Area	Permit Type	Maximum Fee
APP	Individual or area-wide	\$285,400
APP	Complex modification to individual or area-wide	\$214,050
APP	Clean closure of facility	\$71,350
APP	Standard modification to individual or area-wide (per modification up to the maximum fee, and modification can be reassigned under A.A.C. R18-1-516):	
	<ul style="list-style-type: none"> ● Maximum fee (cumulative per submittal) 	\$214,050
	<ul style="list-style-type: none"> ● Modification under A.A.C. R18-9-A211(C)(1) through (3) 	No fee
	<ul style="list-style-type: none"> ● Modification under A.A.C. R18-9-A211(C)(4) through (6) 	\$7,135
	<ul style="list-style-type: none"> ● Modification under A.A.C. R18-9-A211(C)(7), (D)(2)(b) through (i), and (k) through (l) 	\$21,405
	<ul style="list-style-type: none"> ● Modification under A.A.C. R18-9-A211(D)(2)(a) and (j) 	\$35,675
	<ul style="list-style-type: none"> ● Modification under A.A.C. R18-9-A211(B) that is not classified as complex modification under R18-14-101(2) 	\$35,675

APP	<p>For an APP issued before July 1, 2011, the fee for a submittal required by a compliance schedule is assessed per submittal and cumulative up to the maximum fee. The applicable maximum fee for all compliance schedule submissions shall be according to one of the three maximum fee categories listed below. The maximum fee is for the lifetime of the APP unless a new compliance schedule is established in the APP due to a modification that is classified as both a significant amendment under A.A.C. R18-9-A211(B) and a complex modification under R18-14-101(2).</p> <ul style="list-style-type: none"> For a permit with a compliance schedule where one or more submissions require a permit modification that requires a determination or reevaluation of BADCT, the fee is assessed as described above for each standard modification, with a maximum fee for the permit's entire compliance schedule of: For a permit with a compliance schedule where one or more submissions require a permit modification, but no determination or reevaluation of BADCT is required, the fee is assessed as described above for each standard modification, with a maximum fee for the permit's entire compliance schedule of: For a permit with a compliance schedule requiring one or more submissions that require ADEQ review but do not require a permit modification, the maximum fee for the permit's entire compliance schedule is: 	
		\$214,050
		\$142,700
		\$142,700
APP	For an APP issued on or after July 1, 2011, the fee for a submittal required by a compliance schedule is assessed per submittal and cumulative up to the maximum fee for the lifetime of the APP	\$142,700
APP	Determination of applicability	\$21,405
APP	Reviewing proprietary and other reviewed products under A.A.C. R18-9-A309(E)	\$21,405
AZPDES	Individual permit for municipal separate storm sewer system	\$57,080
AZPDES	Individual permit for wastewater treatment plant (based on gallons of discharge per day)	
	<ul style="list-style-type: none"> 3,000 to 99,999 	\$21,405
	<ul style="list-style-type: none"> 100,000 to 999,999 	\$28,540
	<ul style="list-style-type: none"> 1,000,000 to 9,999,999 	\$42,810
	<ul style="list-style-type: none"> 10,000,000 or more 	\$71,350
AZPDES	Individual permit for a facility or activity that is not a wastewater treatment plant or a municipal separate storm sewer	\$42,810
AZPDES	Amendment to an individual permit	\$17,838

AZPDES	Approval of a new or revised pretreatment program under AZPDES	\$14,270
AZPDES	Consolidated individual permit for multiple AZPDES individual permits, as allowed under A.A.C. R18-9-B901(C)	Aggregate of the applicable maximum fees
Reclaimed	Reclaimed water individual permit	\$45,664
UIC	Area	\$200,000
	Area Modification / Renewal	\$150,000
UIC	Classes I, II, III, V Individual	\$200,000
	Classes I, II, III, V Modification / Renewal	\$150,000
UIC	Classes VI Individual	No Max
	Classes VI Modification	No Max
<u>AWP</u>	<u>Permit</u>	<u>No Max.</u>
<u>AWP</u>	<u>Demonstration Permit</u>	<u>No Max.</u>
<u>AWP</u>	<u>Significant Amendment / Renewal</u>	<u>No Max.</u>
<u>AWP</u>	<u>Demonstration Permit Significant Amendment / Renewal</u>	<u>No Max.</u>

R18-14-104. Annual Fees for Water Quality Protection Services Subject to Hourly Rate Fee

- A. Annual Registration Fees. The annual registration fee required under A.R.S. § 49-242 is in Table 2, adjusted annually under subsection ~~(E)~~(F).
- B. The Department shall assess an annual fee for an AZPDES related water quality protection service subject to an hourly rate fee as listed in Table 3, adjusted annually under subsection ~~(E)~~(F).
- C. The Department shall assess an annual fee of \$714, adjusted annually under subsection ~~(E)~~(F) for an individual reclaimed water permit.
- D. The Department shall assess an annual fee and an annual waste disposal fee as applicable to UIC regulated facilities, subject to an hourly rate fee, as listed in Tables 3.1 and 3.2, adjusted annually under subsection ~~(E)~~(F).
- E. The Department shall assess an annual fee of \$101,250, adjusted annually under subsection (F), for AWP permits and for AWP Demonstration permits.
- ~~EE.~~ The Director shall adjust the annual fees listed in subsections (A), (B), (C), (D), and (E) every August 1, to the nearest \$10, beginning August 4, 2023, by multiplying the annual fee by the Consumer Price Index (CPI) for the most recent year, and then dividing by the CPI for the year 2023. The CPI for any year is the average of the Consumer Price Index for All Urban Consumers,

Phoenix-Mesa-Scottsdale, AZ, all items published by the United States Department of Labor, as of the close of the 12-month period ending on June 30 of that year.

Pre-Publication